



Engine

Section 03-09

Komatsu has made every effort to make this manual as accurate as possible based on the information available at the time of publication and printing. Continuous improvement and advancement of product design may cause changes to machines, which may not have been included in this publication. Komatsu reserves the right to make changes and improvements at any time. To ensure the most current information, please contact your service center.

Table of Contents

Scope of This Publication	3
Customer Responsibilities and Warranty Advisories	3
Safety.....	5
Safety, Warnings and Cautions	5
Environmental Precautions.....	7
Theory of Operation.....	9
Component Description	11
Engine.....	11
Fuel and Fuel System.....	12
Fuel Grade Selection	12
Grade 1-D	12
Grade 2-D	12
Fuel Quality Selection Criteria	12
Cetane Rating.....	12
Fuel Sulfur Content.....	13
Fuel Operating Temperature and Viscosity.....	13
Distillation	13
Final Boiling Point.....	13
Other Selection Criteria	13
Emergency Fuels.....	14
Fuel Blending.....	14
Winter Fuel Problems	15
Loss of Engine Power.....	15
Fuel Wax (Cloud Point).....	15
Water Contamination	15
Engine Idling	16
Fuel Storage	16
Water Contamination in Storage	16
Storage Reservoir Maintenance	16
Storage Tank Construction	16
Microbial Contamination of Fuel	17
Fuel Additives	18
Safety in Fueling Operations	19
Fueling the Machine	20
Fuel Cooler - Cummins Engines Only	21
Fuel Tank Check Valve.....	22
Fuel Filter.....	22
Cooling System.....	29

Safety in Cooling System Maintenance 29

Engine Exhaust Wrap 30

Troubleshooting 31

 Cooling System 31

 Corrosion 31

 Coolant, Antifreeze and Rust Inhibitors 32

 Supplemental Coolant Additives (SCA or DCA) 33

 Radiator Inspection and Exterior Cleaning 33

 Radiator Cap 34

 Leaks and Contamination 34

 Thermostats 35

 Hoses 36

 Water Pump 36

 Filters 37

 Accessory Drive Belts and Fan Service 37

 Aeration 37

 Exhaust Gas Leakage 38

 Flushing the Cooling System 38

 Flushing Procedures 38

 Cooling System External Monitoring 39

 Engine Air Restriction Gauges 40

 Engine Safety Adapter 41

 Engine Exhaust Stacks Guard Assembly 42

Vendor Literature 43

 VL124 – L&M Mesabi Service Manual for Oil Cooler 43

 VL125 – L&M Mesabi Service Manual for Radiator 43

 VL132 – Mesabi Service Manual for Copper Tube 43

List of Figures

Figure 1. Engine serial number location 11

Figure 2. Typical fuel filler location 19

Figure 3. Typical central service system (optional) 20

Figure 4. Fuel cooler core - Cummins engine only 21

Figure 5. Typical fuel filter 22

Figure 6. L-1350 typical fuel system installation (Detroit Diesel) 23

Figure 7. L-1350 typical fuel system installation (Cummins) 25

Figure 8. L-1850/L-2350 typical fuel system layout (Detroit Diesel) 26

Figure 9. L-1850/L-2350 typical fuel system layout (Cummins) 27

Figure 10. Surge tank release ball valve 29

Figure 11. Radiator surge tank (typical view) 34

Figure 12. Radiator piping hose installation (typical) 36

Figure 13. Typical coolant conditioning filters 37

Figure 14. Central service system (opt.) 39

Figure 15. Engine filter restriction gauges 40

Figure 16. Engine filter restriction gauge location 40

Figure 17. Reset button located on bottom of restriction gauge 41

Figure 18. Engine filter safety adapter location 41

Figure 19. Engine exhaust stacks guard assembly 42

Scope of This Publication

Proper fuel selection, maintenance, and storage have great importance in the life of diesel-powered machines. Following these recommendations will help to increase production, reduce maintenance expenses and increase the life of the engine.

Proper maintenance of the cooling system is critical to the service life of diesel-powered machines.

NOTICE

In addition to these general instructions, it is **IMPORTANT** to refer to the engine manufacturer's recommendations regarding proper fuel, storage, oil and filter change intervals, and general engine maintenance.

Customer Responsibilities and Warranty Advisories

P&H wheel loaders are warranted in accordance with the warranty policy provided with the machine. The recommended operating and maintenance procedures set forth shall be followed to ensure warranty coverage is not jeopardized. Failure to comply with recommended operating and maintenance procedures may void machine warranty.

Any questions or problems relating to warranty policy or administration should be directed to Komatsu Service Center. Include the model and serial number, in-service date of the machine, and hour meter reading. **We especially draw your attention to the following safety advisories.**

This Page Intentionally Left Blank

Safety

This publication contains special instructions that pertain to safety, operation, maintenance, and repair of the machine. Listed below are the signal words and symbols that precede these instructions and their meanings:

DANGER

- The danger label indicates a hazardous situation which, if not avoided, will result in death or serious injury.

WARNING

- The warning label indicates a hazardous situation which, if not avoided, could result in death or serious injury.

CAUTION

- The caution label, used with the safety alert symbol indicates a hazardous situation which, if not avoided, could result in minor or moderate injury (includes the safety alert symbol .

CAUTION

- The caution label (without safety alert symbol) is used to address practices not related to personal injury – only equipment damage.

NOTICE

The NOTICE graphic is to indicate areas of importance to the reader that are not related to personal injury or machine damage.

Safety, Warnings and Cautions

WARNING

INHALATION AND EXPLOSION HAZARDS

- Inhalation and explosion hazards exist inside the cab if spraying ether-starting aid into the air intake of the Komatsu Cartridge Filtration System (KLENZ™ system). The KLENZ system provides fresh air to the cab (and other components). Inhalation of ether fumes is dangerous and can render a person unconscious or cause death. Ether fumes are extremely flammable. They can build up inside the cab and cause an explosion. Never use ether starting aid to start the engine. The use of ether is NOT recommended by Komatsu as an engine starting aid. Using ether starting aid in the engine intake can cause an inhalation and explosion hazard resulting in serious injury or death.

INHALATION AND SKIN HAZARDS

- Inhalation and skin hazards exist if contacting microbes or fungi from a fuel reservoir. When a fuel tank is contaminated, and cleaning is necessary, workers must be protected with breathing apparatuses. The most common problem associated with exposure to these microorganisms is dermatitis, which can be very serious. Any exposed skin must be thoroughly washed with warm,

soapy water. Avoid eating, drinking and smoking while working with contaminated tanks. Any ingestion of microorganisms or exposure to broken skin must be considered serious. It is recommended that if this happens the worker be taken to a doctor, along with a sample of the microorganisms. Failure to prevent inhalation or skin contact with microbes or fungi can cause inhalation and skin hazards resulting in serious injury or death.

INHALATION HAZARD

- Inhalation hazard exists when working around engine exhaust. Always have proper ventilation when working around engine exhaust. Failure to use proper ventilation can cause inhalation hazard resulting in serious injury or death.

WARNING: Breathing diesel engine exhaust exposes you to chemicals known to the State of California to cause cancer and birth defects or other reproductive harm.

- Always start and operate the engine in a well-ventilated area.
- If in an enclosed area, vent the exhaust to the outside.
- Do not modify or tamper with the exhaust system.
- Do not idle the engine except as necessary.

For more information go to www.P65warnings.ca.gov/diesel.

CRUSH HAZARD

- Crush hazards exist if the machine is started or moved while work processes are being performed on the machine. Place bucket flat and level on the ground. Place frame lock in the locked position and lock out the machine's starting capability before performing any work process. Follow all applicable lockout procedures and local rules and regulations for performing work processes. ANYONE performing inspections or service procedures to the machine should be familiar with ALL instructions and procedures contained in the machine's SERVICE MANUAL. Crush hazard could occur if the machine is started or moves while any type of work process is being conducted on the machine, resulting in serious injury or death.

BURN HAZARD

- Burn hazard exists when working on or around hot cooling systems. Liquid cooling systems build up pressure, as the engine gets hot. Before removing the radiator cap, stop the engine and let the system cool. Remove the radiator cap or surge tank cap only after the coolant is cold. Failure to allow the coolant to cool can result in serious burns.
- Burn hazard exists if removing the radiator cap on a hot radiator. Wait for the coolant to cool before removing an engine radiator cap or engine coolant surge reservoir cap. Serious injury may result from escaping steam and hot coolant. On machines that utilize surge reservoirs, turn the ball valve to release the pressure before removing surge reservoir cap. Failure to wait for the coolant to cool can cause burn hazards resulting in serious burn injury.

EXPLOSION HAZARD

- Explosion hazards exist if blending gasoline, gasohol, or alcohol (ethanol or methanol) with diesel fuel. Never mix these chemicals together. This practice creates an extreme fire hazard and under certain conditions an explosive hazard. Blending gasoline, gasohol, or alcohol (ethanol or methanol) with diesel fuel can cause a fire or explosion hazard resulting in serious injury or death.
- Explosion hazards exist if spraying ether-starting aid into the air intake of the Komatsu Cartridge Filtration System (KLENZ™ system). Ether fumes are extremely flammable. Never use ether starting aid to start the engine. The use of ether is NOT recommended by Komatsu as an engine starting aid. The KLENZ system provides air to the engine turbos, generator, motors, and cab. Using ether starting aid in the engine intake can cause an explosion hazard resulting in serious injury or death.

 **CAUTION****FIRE HAZARD**

- Fire hazard exists if the fuel reservoir is filled all the way to the top. Fuel expands as it gets warm and may overflow. Stop fueling the reservoir before the level reaches the top of the filler neck. Filling the fuel reservoir to the top can cause a fire hazard resulting in personal injury.

BURN HAZARD

- Burn hazard exists if unwrapping the engine exhaust piping or muffler while hot. Wait for the engine exhaust to cool off before unwrapping the exhaust pipes for inspection. Failure to wait for the exhaust to cool off can cause burn hazards resulting in personal injury.

BURNS AND FALL HAZARDS

- Burns and fall hazards exist if working around the engine exhaust stacks while they are hot. The ends of the stacks extend outside the guard assembly and can be physically touched. Touching the stacks while hot can produce severe burns. Personal injury from burns, or reacting to burns and falling, is possible. Always wear personal protective equipment (PPE) to prevent burns. Failure to avoid touching the stacks can cause burn and fall hazards resulting in injury.

Environmental Precautions

 **WARNING**

Some environmental hazards can exist during the performance of a maintenance, repair, or adjustment procedure. Komatsu cannot anticipate all hazards present during a specific procedure. The following suggestions/requirements are provided to help avoid hazards that may have been identified during some procedures.

- Be prepared to catch/contain and properly dispose of all fluids to prevent environmental spills and contamination. Some examples include:
 - Engine radiator coolant
 - Engine oil
 - Battery acid
 - Engine fuel (diesel)

This Page Intentionally Left Blank

Theory of Operation

P&H wheel loaders use a diesel engine to rotate a generator to power the electric motors, and turn a hydraulic pump drive (HPD). The engine is operated at set throttle speeds. The fuel system is critical to proper operation of the engine. The engine is water cooled by pumping the coolant through a radiator that has a thermostatically controlled fan.

This Page Intentionally Left Blank

Component Description

Engine

Applicable engine service, repair, PM, and parts information related to your specific engine is no longer provided to Komatsu by the engine manufacturers. This information is only available from your local Cummins or Detroit engine dealer.

Please provide your engine serial number to your local engine distributor to determine their options for online access or paper copies.

The serial number is typically located on the engines as shown below.



<p>Detroit Diesel engine: The serial number is typically located on the left side of the engine on the generator end as shown below.</p>	<p>Cummins engine: The serial number is typically located on the left side of the engine on the engine fan end as shown below.</p>
	
<p>Typical location of tag on Detroit Diesel engine</p>	<p>Typical location of tag on Cummins engine</p>

Figure 1. Engine serial number location

Komatsu will also have the SERIAL NUMBER available after installation of the new engine into the machine.

⚠ **WARNING**

Inhalation hazard exists when working around engine exhaust. Always have proper ventilation when working around engine exhaust. Failure to use proper ventilation can cause inhalation hazard resulting in serious injury or death.

WARNING: Breathing diesel engine exhaust exposes you to chemicals known to the State of California to cause cancer and birth defects or other reproductive harm.

- Always start and operate the engine in a well-ventilated area.
- If in an enclosed area, vent the exhaust to the outside.
- Do not modify or tamper with the exhaust system.
- Do not idle the engine except as necessary.

For more information go to www.P65warnings.ca.gov/diesel.

Fuel and Fuel System

NOTICE

Disposal of diesel fuel, used oil, hydraulic fluid, and engine coolant is subject to country, state, and local environmental regulations. Dispose of these items properly through approved reclamation facilities per applicable regulations. DO NOT flush or pour these items into streams or sewer systems. Improper disposal can cause an environmental impact.

Fuel Grade Selection

Diesel engines burn a wide variety of fuels, but use of clean fuel is imperative and selection of the right type is important. The two major grades of diesel fuel are 1-D and 2-D.

Grade 1-D

Grade 1-D is more volatile and is recommended for modern high-speed engines, with variable loads and speeds, as well as for operation in extremely cold weather, or at altitudes above 5000 ft.

Grade 2-D

Grade 2-D is recommended for high-speed engines, with relatively high loads and more uniform speeds, as well as for engines, not requiring the higher volatility of 1-D. Grade 2-D is generally less expensive than 1-D and more widely used.

Fuel Quality Selection Criteria

When evaluating diesel fuel for use in a machine, consider the following items and any others that may be noted in engine manufacturers' manuals or service bulletins.

Some fuels will give better performance, higher efficiency, improved reliability, or lower maintenance costs than others. Fuel must be selected based on overall operating costs, not just the price per gallon.

Most engine manufacturers' specifications refer to the tests done by The American Society for Testing and Materials (ASTM). Their test results are published in their Annual Book of Standards. It is **IMPORTANT** to verify the tests referred to by the manufacturer for various rating criteria are comparable to the test data on the fuel supplied by your fuel vendor.

Insist that the fuel vendor periodically supply the proper documentation to be sure the fuel meets the manufacturer's recommendations and the needs of your specific application. Fuel quality can change with each bulk delivery.

Cetane Rating

Ignition qualities of diesel fuels are measured by the cetane number, which is roughly comparable to the octane rating of gasoline. Cetane ratings are mistakenly used to indicate fuel quality. A high cetane number should not be considered alone when evaluating fuel quality. Cetane ratings vary from 33 to 64. High-cetane fuels permit engines to be started at lower air temperatures and higher altitudes, provide faster engine warm-up without misfiring, reduce varnish and carbon deposits, and help eliminate knock caused by slow ignition. Fuel with too high cetane rating can cause incomplete combustion, which can rapidly dilute and contaminate engine oil.

Fuel Sulfur Content

Fuels with high sulfur content cause rapid deterioration of the engine lubricating oils that protect and cool engine parts, necessitating more frequent oil changes. Engine manufacturers provide their recommendations for allowable fuel sulfur content and normal oil change intervals in their operator's manuals and service manuals. These intervals may vary in length depending on engine operation, fuel quality, and lubricant quality. The proper oil change interval for a specific application may be established by recommendations of an on-going oil analysis program provided by the manufacturer. As an oil analysis program indicates the condition of the engine, it should not be used to extend oil change intervals. The oil should be changed if any contamination is present in concentrations exceeding manufacturer's recommendations. The choice of fuel should be changed to stay within these guidelines if the analysis program indicates it is a source of contamination.

Fuel Operating Temperature and Viscosity

Diesel fuel provides cooling for the injection system. The temperature of the fuel may vary considerably due to the ambient temperature, engine temperature, and the amount of fuel remaining in the tank. As fuel temperature increases, the fuel viscosity, and therefore the lubrication capabilities of the fuel diminish. Maintaining proper fuel temperatures in combination with the selection of fuels with the viscosity ranges recommended by the manufacturer will assure proper injection system functioning. Some systems have an external fuel cooling system.

Distillation

The boiling range is very important in consideration of diesel fuel quality. Many specifications contain a partial listing of the distillation test results, i.e. Distillation Temperature at 90% Recovered etc. Many diesel fuels are blended products that may contain constituents with boiling ranges much different than the majority of the fuel composition. The full boiling range as recommended by the engine manufacturer in the operator's manual or service manual should be closely followed.

Final Boiling Point

Fuel can be burned in an engine only after it has been completely vaporized. The temperature at which the fuel is completely vaporized is described as the End Point Temperature. This temperature must be low enough to permit complete vaporization at combustion chamber temperatures. The combustion chamber temperature depends on ambient temperature, engine speed, and load. Poor vaporization is more likely to occur during severe cold weather, prolonged idling, and light operation. Engines operating under these conditions should use fuels with lower distillation end point temperatures.

Other Selection Criteria

There are several other items to consider in the selection of fuel, which are listed in most engine manufacturer's requirements. These include:

Water and sediment: The amount of water and solid debris in the fuel is generally classified as water and sediment. It is good practice to filter fuel while it is being put into the tank.

More water vapor condenses in partially filled tanks due to breathing caused by temperature changes. Filter elements, fuel screens in the fuel pump, and fuel inlet connections on injectors must be cleaned or replaced whenever they become dirty. These screens and filters, in performing their intended function, will become clogged when using a poor or dirty fuel and will need to be changed more often.

Density: Gravity is an indication of the high-density energy content of the fuel. A fuel with a high density (low API gravity) contains more BTUs per gallon than a fuel with a low density (higher API gravity).

Carbon Residue: The tendency of a diesel fuel to form carbon deposits in an engine can be estimated by determining the Ramsbottom or Conradson carbon residue of the fuel after 90 percent of the fuel has been evaporated.

Cloud Point: The cloud point of the fuel is the temperature at which crystals of paraffin wax first appear. Crystals can be detected by a cloudiness of the fuel. These crystals will cause filters to clog.

Ash: The small amount of non-combustible metallic material found in almost all petroleum products is commonly called ash.

Acid Number: Using fuel with higher acid numbers can lead to higher than desirable levels of wear.

Emergency Fuels

Most manufacturers provide specifications and tolerances for fuel that must be used in an emergency situation where the recommended fuel is not available. Use of these fuels can have an adverse effect on engine performance and durability. They are meant to be used for short periods of time when no other fuels are available. Refer to the engine manufacturer's manuals, technical service bulletins, authorized distributors, and fuel supplier for information on emergency fuels.

Fuel Blending

CAUTION

Refer to the engine manufacturer's manuals and technical bulletins and consult with authorized distributors and your fuel supplier before blending any fuel for use in the machine.

Three common practices of fuel blending are:

The first is the blending of heavier fuels with lighter fuels to lower the wax content, cloud point, and pour point, and thus improve cold weather operation.

The second is the blending of NEW engine lubricating oil with fuel to increase the viscosity.

The third is the blending of USED engine lubricating oil to reduce fuel costs and to aid in disposing of used engine oil.

CAUTION

Some manufacturers specifically DO NOT recommend blending USED lubrication oil with diesel fuel and others have allowable specifications. Refer to the engine manufacturer's manuals and technical bulletins or consult with authorized distributors before blending used lubricating oil with diesel fuel for use in the machine.

WARNING

Explosion hazards exist if blending gasoline, gasohol, or alcohol (ethanol or methanol) with diesel fuel. Never mix these chemicals together. This practice creates an extreme fire hazard and under certain conditions an explosive hazard. Blending gasoline, gasohol, or alcohol (ethanol or methanol) with diesel fuel can cause a fire or explosion hazard resulting in serious injury or death.

Winter Fuel Problems

The two major winter fuel problems encountered by owners and operators of diesel-powered equipment are wax and ice. There is no solution to either of these problems, which is ideal for all situations. The following troubleshooting information should help with these problems.

Loss of Engine Power

Determining whether a low power complaint is due to a fuel filter-plugging problem is somewhat simple. Replace the fuel filter with a new one. If this allows the machine to operate normally, even for a short time period, then obviously something in the fuel is plugging the filter and causing the problem.

A simple way to determine whether the filter plugging is caused by wax or ice is to bring the plugged filter into a warm shop, drain out the liquid fuel, place the filter upside down on a piece of paper or in a shallow pan, and allow the filter to warm to room temperature. If ice is the problem, it will melt and run out of the filter and the water on the paper or in the pan will be obvious. Most petroleum wax will not melt at room temperature. To speed the process, the filter can be cut open and spread out. Once the cause of the problem is determined, then a logical solution can be chosen.

Fuel Wax (Cloud Point)

All diesel fuel contains paraffin wax. This paraffin occurs naturally in the crude oil from which diesel fuel is distilled. The wax content of diesel fuel varies depending on the crude from which it was produced and in its processing. Because of the strong relationship between temperature and solubility of wax, wax separation is a problem in handling and using diesel fuel during cold weather.

As fuel cools, a temperature is reached at which the fuel becomes saturated with wax; and any further cooling will cause wax to separate out of solution. The temperature at which the solution is saturated is the cloud point. If fuel is cooled below the cloud point, the fuel becomes so thick it will no longer flow. This temperature is the Pour Point. At the Pour Point, most of the fuel is still liquid although it is very thick or viscous and trapped in a honeycomb-like network of wax crystals.

Wax in the fuel will deposit in any restriction or sharp bend in the fuel plumbing system. If fuel starvation occurs during cold weather operation and plugged fuel filters do not seem to be the problem, look for plugging of tank pickup screens, sharp bends in the fuel lines, fittings, etc.

Water Contamination

Free water (non-dissolved) in the fuel can freeze at low temperatures and the resulting ice crystals can plug fuel filters causing fuel starvation.

Water can get into a diesel engine's fuel system in two ways:

1. Water can be in the storage tank and be entrained when filling the machine's fuel tank. Care must be taken to keep fuel storage tanks free of condensate.
2. Water, or moisture, in the air above the fuel can condense on the walls of the fuel tank. Condensation in the machine's fuel tank occurs when the air in the tank cools down during a shutoff period.

NOTICE

Refer to FUEL STORAGE and FUEL ADDITIVES, located within this section, for IMPORTANT information concerning proper fuel storage, fuel additives and fueling procedures that relate to water contamination.

Engine Idling

Avoid unnecessary engine idling. During long engine idling periods (10 minutes or more), the engine coolant temperature will fall below the normal operating range. The incomplete combustion of fuel in a cold engine will cause crankcase dilution; formation of lacquer or gummy deposits on the valves, pistons, and rings and rapid accumulation of sludge in the engine.

Fuel Storage

CAUTION

Proper fuel storage is extremely important. Many diesel engine difficulties can be traced to dirty or contaminated fuel or fuel that has been in storage too long.

Water Contamination in Storage

Diesel fuel oxidizes in the presence of air and water. The oxidation of fuel can result in the formation of undesirable gums and sediment. Such undesirable deposits can cause filter plugging, combustion chamber deposit formation and gumming or lacquering of injection system components with resultant sticking or wear.

Storage Reservoir Maintenance

Storage reservoirs and stored fuel should be inspected regularly for dirt, water, scale, sludge, and other foreign matter; and cleaned if necessary. Drain and flush storage reservoirs periodically. Water will condense in partially filled reservoirs.

NOTICE

Fuel storage reservoirs should be tested often with water detecting paste (usually obtainable from fuel vendors) to be sure they are dry. If water is detected, it must be pumped out and what remains must be treated with anhydrous isopropyl alcohol or methoxy ethanol to prevent freezing. It is IMPORTANT to refer to engine manufacturer's manuals, technical bulletins, or consult with authorized distributors to determine the correct approach before treating the fuel with these additives.

Storage Tank Construction

Diesel storage reservoirs can be constructed of aluminum, monel, stainless steel, black iron, welded steel, or reinforced (non-reactive) plastic. The storage reservoirs should have provision for draining water that settles in their bottoms.

CAUTION

A galvanized steel tank should NEVER be used for fuel storage because the fuel reacts chemically with the zinc coating to form powdery flakes which can quickly clog the fuel strainer and filter and damage the fuel pump and injectors.

NOTICE

If keeping water out of bulk storage tanks is a persistent problem, a drier (fuel/water separator) should be installed on the bulk fuel dispensing system.

Microbial Contamination of Fuel

Microbial contamination of the fuel occurs primarily in bulk storage facilities. Typically, it is passed into the fuel system of machines during the fueling process. These microorganisms, primarily bacteria and fungi, exist rather harmlessly in moisture-free fuel, passing through fuel systems without causing any problems. However, in the presence of water, these microorganisms begin to grow and reproduce. The rate of growth depends on how well the environment suits the particular organism's needs. An improperly maintained fuel tank on a machine is an ideal place for these microorganisms to flourish.

Microbial contamination of a fuel system can cause several problems.

The first and usually most obvious is fuel filter plugging with a greenish-black or brown slime, frequently accompanied by a foul odor. This slimy, string-like colony can also plug sharp bends in fuel lines, fuel meters, and other restrictions.

The second problem these microorganisms cause is corrosion due to the acid by-products some of them produce.

The third problem is that if the microorganisms pass through the fuel filter, they will form deposits and cause damage in the fuel pump and injectors.

The best way to verify the presence of microbial contamination is to use a commercially available test kit, on a routine basis. These test kits can detect microorganisms before there is any evidence of a problem.

CAUTION

There are several micro biocide additives commercially available and it is **IMPORTANT** to refer to the manufacturer's manuals and technical bulletins and consult with authorized distributors and your fuel supplier before treating your fuel for microbial contamination.

WARNING

Inhalation and skin hazards exist if contacting microbes or fungi from a fuel reservoir. When a fuel tank is contaminated and cleaning is necessary, workers must be protected with breathing apparatuses. The most common problem associated with exposure to these microorganisms is dermatitis, which can be very serious. Any exposed skin must be thoroughly washed with warm, soapy water. Avoid eating, drinking and smoking while working with contaminated tanks. Any ingestion of microorganisms or exposure to broken skin must be considered serious. It is recommended that if this happens the worker be taken to a doctor, along with a sample of the microorganisms. Failure to prevent inhalation or skin contact with microbes or fungi can cause inhalation and skin hazards resulting in serious injury or death.



NOTICE

Environmental hazards exist if placing removed contaminants into sewer systems. The contaminants such as microorganisms can kill bacteria used in sewage treatment. **NEVER** place these contaminants in storm sewers or surface water streams as they can kill fish and other aquatic animals. Follow all local rules, regulations, and laws to dispose of contaminants. Some laws may require expensive fines or imprisonment. Failure to follow all local rules, regulations, and laws to dispose of contaminants can cause an environmental hazard resulting in environmental damage.

Fuel Additives

Great care must be exercised in the choice and use of additives. Some fuel additives can be harmful to the engine. Most legitimate fuel additives perform only one function. Multi-functional fuel additives are mixtures of several additives. All fuel additives perform differently in different fuels; therefore, the additive used must be one to which the fuel will respond.

NOTICE

There are no known additives that can increase power or improve the efficiency of a properly maintained engine.

CAUTION

Fuel additives should NOT be used unless specifically recommended by the engine manufacturer.

Some fuel additives provide temporary benefits but do not replace good fuel handling practices. Such additives are helpful when water or microbial contamination is suspected:

Isopropyl alcohol and methoxy ethanol is designed for treatment of water contamination and prevention of ice crystal formation. Refer to the engine manufacturer's guidelines for the amount to be mixed with the fuel. Refer to "Fuel Storage", within this section, for additional information on the use of these additives.

Microbiocide additives - for treatment of microbe growth or black "slime". Follow the manufacturer's instructions for treatment. Refer to "Microbial Contamination of Fuel", within this section, for additional information concerning the use of micro biocide additives.



WARNING

Explosion hazards exist if blending gasoline, gasohol, or alcohol (ethanol or methanol) with diesel fuel. Never mix these chemicals together. This practice creates an extreme fire hazard and under certain conditions an explosive hazard. Blending gasoline, gasohol, or alcohol (ethanol or methanol) with diesel fuel can cause a fire or explosion hazard resulting in serious injury or death.

NOTICE

Refer to **FUEL BLENDING**, within this section, for additional information and cautions concerning blending of diesel fuel.

WARNING

Explosion hazards exist if spraying ether-starting aid into the air intake of the Komatsu Cartridge Filtration System (KLENZ™ system). Ether fumes are extremely flammable. Never use ether starting aid to start the engine. The use of ether is NOT recommended by Komatsu as an engine starting aid. The KLENZ system provides air to the engine turbos, generator, motors, and cab. Using ether starting aid in the engine intake can cause an explosion hazard resulting in serious injury or death.

WARNING

Inhalation hazard exists inside the cab if spraying ether-starting aid into the air intake of the Komatsu Cartridge Filtration System (KLENZ™ system). The KLENZ system provides fresh air to the cab (and other components). Inhalation of ether fumes is dangerous and can render a person unconscious or cause death. Ether fumes are extremely flammable. Never use ether starting aid to start the engine. The use of ether is NOT recommended by Komatsu as an engine starting aid. Using ether starting aid in the engine intake can cause an inhalation hazard resulting in serious injury or death.

Safety in Fueling Operations

These guidelines should be followed in the routine fueling of the machine to ensure safe operations:

Fuel leaks and spills are a fire hazard. They should be noted and reported during routine inspections. Should a leak or spill be discovered, correct the problem and clean the affected area before operating the machine.



- a. NEVER smoke while checking the fuel level or refueling. Unguarded trouble lights, flames, or spark producing devices should be kept at a safe distance while fueling.
- b. NEVER use an open flame to check fuel level or for a leak on the machine. Use an ignition proof light source.
- c. ALWAYS stop the engine while fueling the machine.
- d. The fueling facility should be in a well-ventilated and well-lighted location.



- e. Learn the location and operation of the fire extinguisher closest to the fueling facility.



Figure 2. Typical fuel filler location

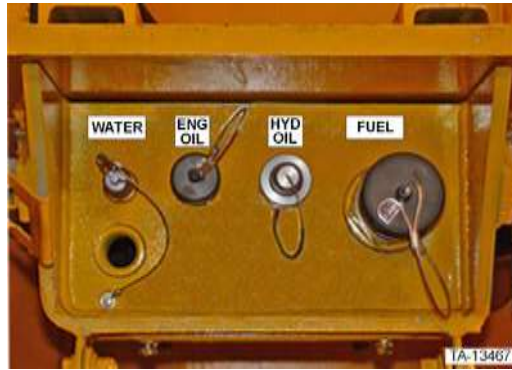

(left side of rear frame)

Figure 3. Typical central service system (optional)

Fueling the Machine

The machine has a fuel filler neck located at the left side the rear frame. An optional central service system is available, which provides a quick connect fitting for fueling the machine. The central service system is also located at the left side of rear frame.

CAUTION

The best fuel, if contaminated by dirt or water, can damage an engine. Refer to text “Fuel Storage”, within this section, for additional information concerning contamination of diesel fuel.

- a. Fueling should never take place in a locale where dust, dirt, or water can enter an open fuel reservoir.
- b. Dust, dirt, and water should be wiped away from the machine’s fuel reservoir and cap before opening.
- c. The machine’s fuel reservoir should be drained periodically to eliminate water which condensates in the reservoir and settles in the bottom.

NOTICE

The machine should be refueled after each shift to prevent condensate from accumulating in the reservoir and contaminating the fuel.



⚠ CAUTION

Fire hazard exists if the fuel reservoir is filled all the way to the top. Fuel expands as it gets warm and may overflow. Stop fueling the reservoir before the level reaches the top of the filler neck. Filling the fuel reservoir to the top can cause a fire hazard resulting in personal injury.

Fuel Cooler - Cummins Engines Only

Machines equipped with Cummins engines have a fuel cooler that cools the fuel being returned to the fuel tank. The cooler core is mounted behind the engine radiator (refer to illustration "FUEL COOLER CORE – CUMMINS ENGINE ONLY"). When the fuel's viscosity level indicates the need for cooling, the fuel is routed through the cooling core via a 4-psi check valve and then to the fuel tank. Check fuel cooler frequently for a buildup of dust and dirt. Clean with a high-pressure washer or steam cleaner as required.

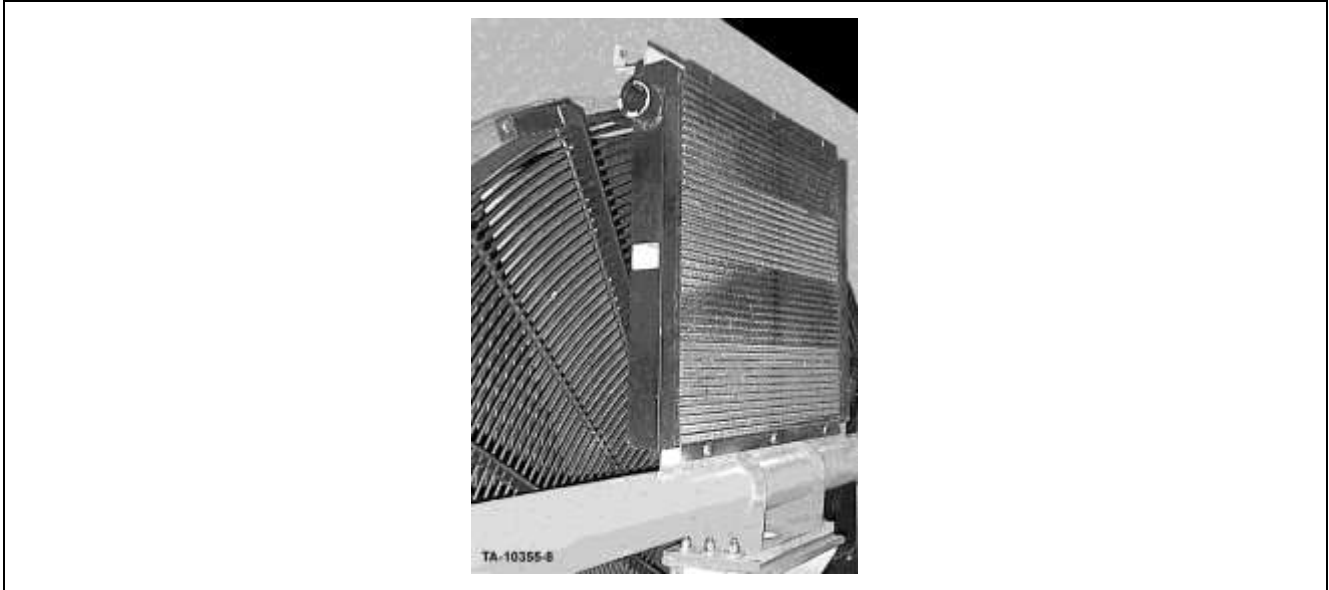

Figure 4. Fuel cooler core - Cummins engine only

Fuel Tank Check Valve

The machine is equipped with a fuel line check valve(s), located on the fuel tank, at the right rear of the machine. Detroit Diesel equipped machines have one check valve and Cummins engine equipped machines have two check valves. Every 1000 hours of operation, remove, inspect, and clean the valve(s) as required.

Fuel Filter

It is essential to replace the fuel filters per the engine manufacturer’s recommendations outlined in the engine owner’s manual. The location of fuel filters varies with the engine manufacturer. The engine owner’s manual is available on the manufacturer’s website.

Some machines can be optionally equipped with a fuel filter system that consists of a permanently mounted, replaceable filter. The unit is mounted on the right side of the rear frame in most applications (refer to illustration "Typical fuel filter" below). The filter must be replaced every 500 hours of operation. Instructions for replacing the filter are included in the manufacturer’s product information.

NOTICE

The Cummins filter system has an indicator zone that indicates when the filter should be changed.

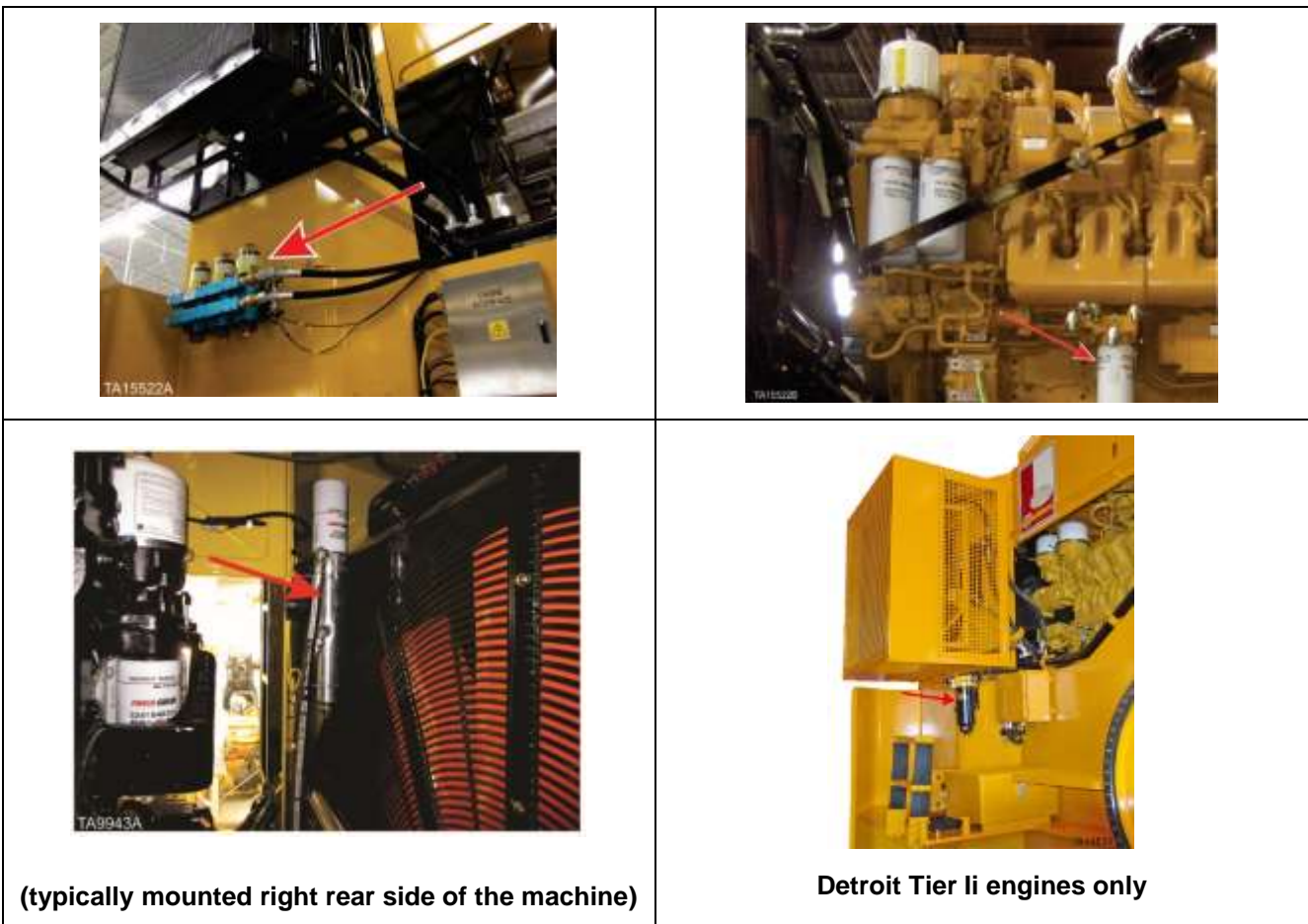
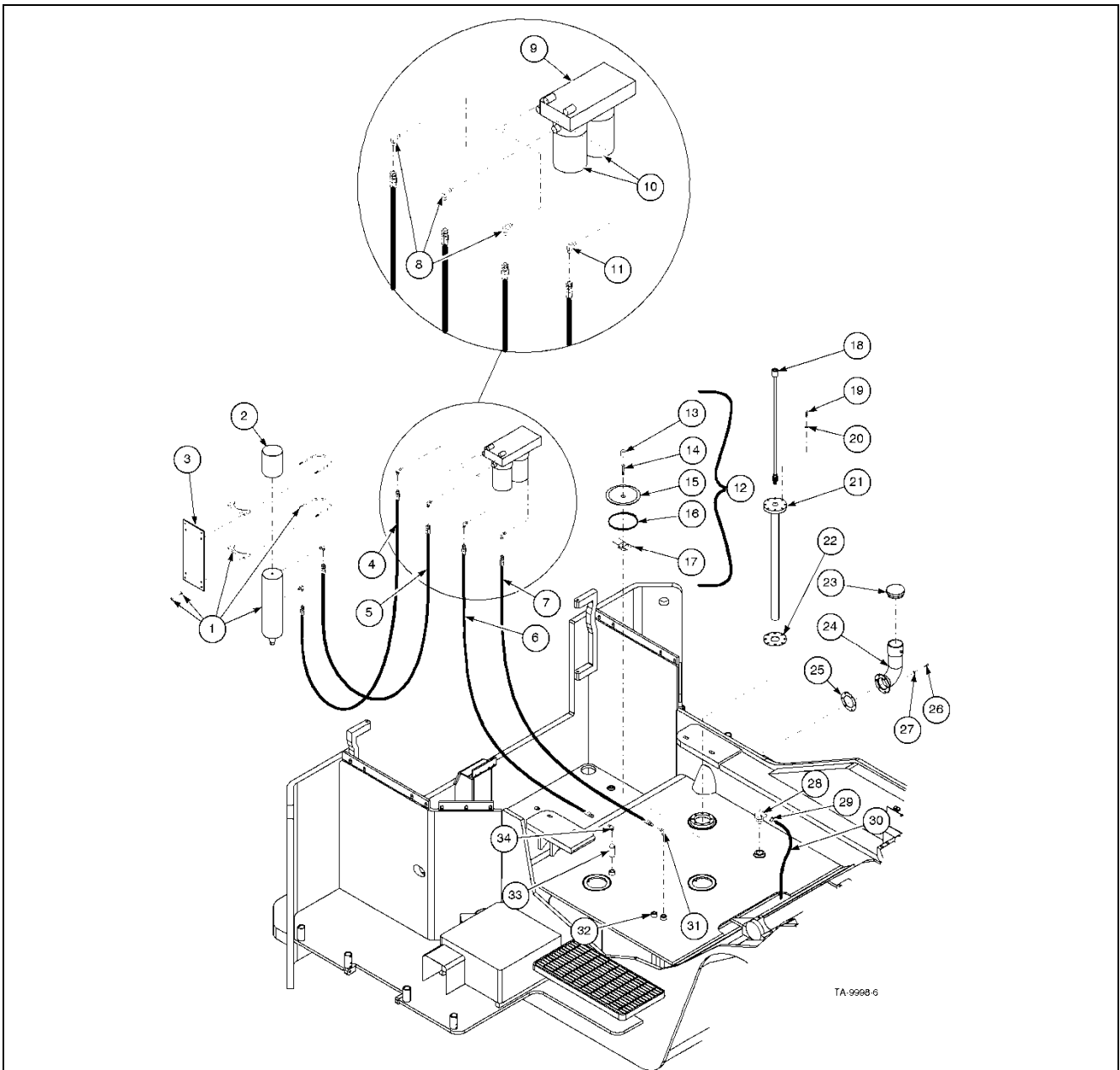

Figure 5. Typical fuel filter



1. Filter Assembly	12. Cover Assembly	23. Filler Neck
2. Fuel Filter	13. Pipe Plug	24. Gasket
3. Mount Plate	14. Capscrew	25. Bolt
4. Hose Assembly	15. Cover Structure	26. Lockwasher
5. Hose Assembly	16. O-Ring	27. Vent Assembly
6. Hose Assembly	17. Clamp Structure	28. Clamp
7. Hose Assembly	18. Sending Unit, Fuel Level	29. Hose
8. Elbow	19. Bolt	30. Elbow
9. Filter Mount	20. Flatwasher	31. Pipe Plug
10. Fuel Filter	21. Mount Structure	32. Check Valve
11. Elbow	22. Gasket	33. Elbow

Figure 6. L-1350 typical fuel system installation (Detroit Diesel)

On the model L-1350 loader, the fuel tank is an integral part of the rear frame

This Page Intentionally Left Blank

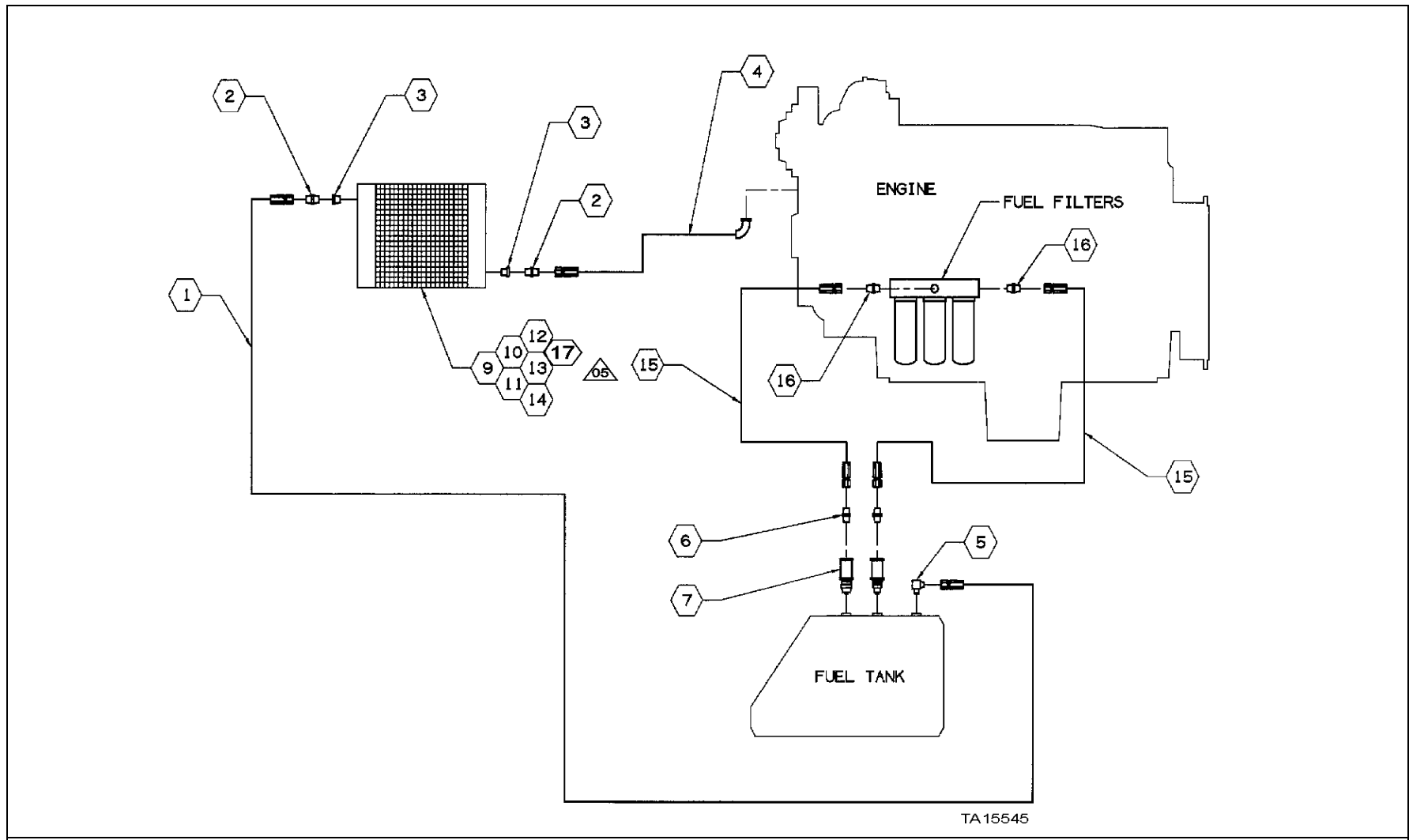

1) Hose, 2) Hydraulic Fitting, 3) Hydraulic Fitting, 4) Hose, 5) Hydraulic Fitting, 6) Hydraulic Fitting, 7) Fuel Check Valve Kit, 9) Fuel Cooler, 10) Oil Cooler Brace Bar, 11) Hex Bolt, 12) Flatwasher, 13) Lockwasher, 14) Hex Nut, 15) Hose, 16) Hydraulic Fitting, 17) Oil Cooler Mount Bar

Figure 7. L-1350 typical fuel system installation (Cummins)

On the model L-1350 loader, the fuel tank is an integral part of the rear frame

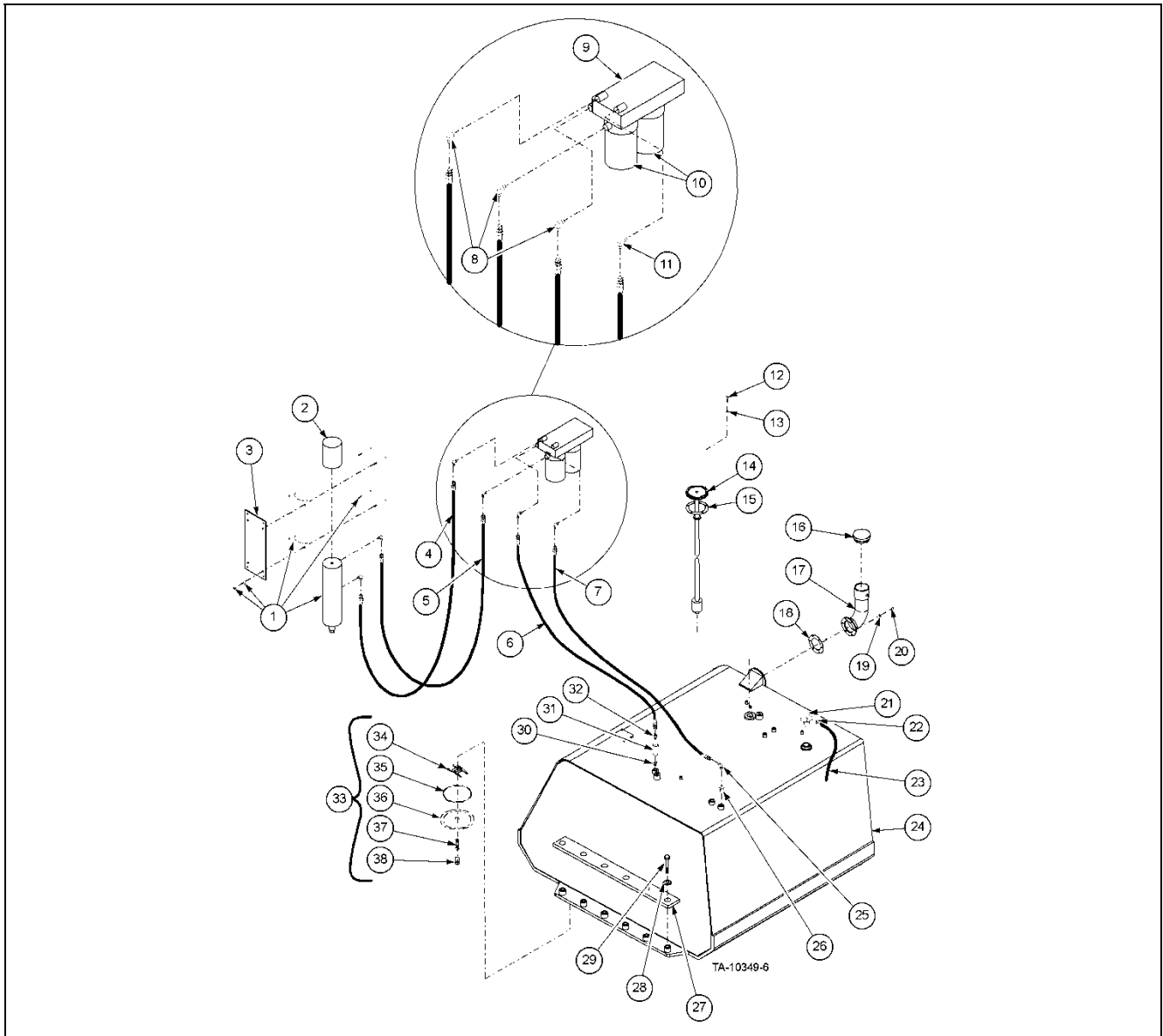

<ul style="list-style-type: none"> 1. Filter Assembly, DAVCO 2. Filter, Fuel 3. Mount Plate, Filter Assembly 4. Hose Assembly 5. Hose Assembly 6. Hose Assembly 7. Hose Assembly 8. Elbow - Swivel 9. Filter Mount 10. Filter, Fuel 11. Elbow - Swivel 12. Screw 13. Lockwasher 	<ul style="list-style-type: none"> 14. Sending Unit, Fuel Level 15. Gasket, Fuel Sending Unit 16. Cap Assembly, Fuel 17. Filler Neck Structure, Fuel Tank 18. Gasket, Filler Neck 19. Lockwasher 20. Bolt 21. Vent Assembly 22. Clamp, Hose - Worm 23. Hose 24. Tank Structure, Fuel 25. Elbow 26. Bushing 	<ul style="list-style-type: none"> 27. Spacer Bar, Fuel Tank Mount 28. Lockwasher 29. Bolt 30. Nipple, Pipe 31. Valve Kit, Check - Fuel 32. Adapter 33. Cover Assembly, Access - Fuel Tank 34. Clamp Structure 35. O-Ring 36. Cover Structure 37. Capscrew 38. Plug, Pipe, Hex Csk.
--	---	---

Figure 8. L-1850/L-2350 typical fuel system layout (Detroit Diesel)

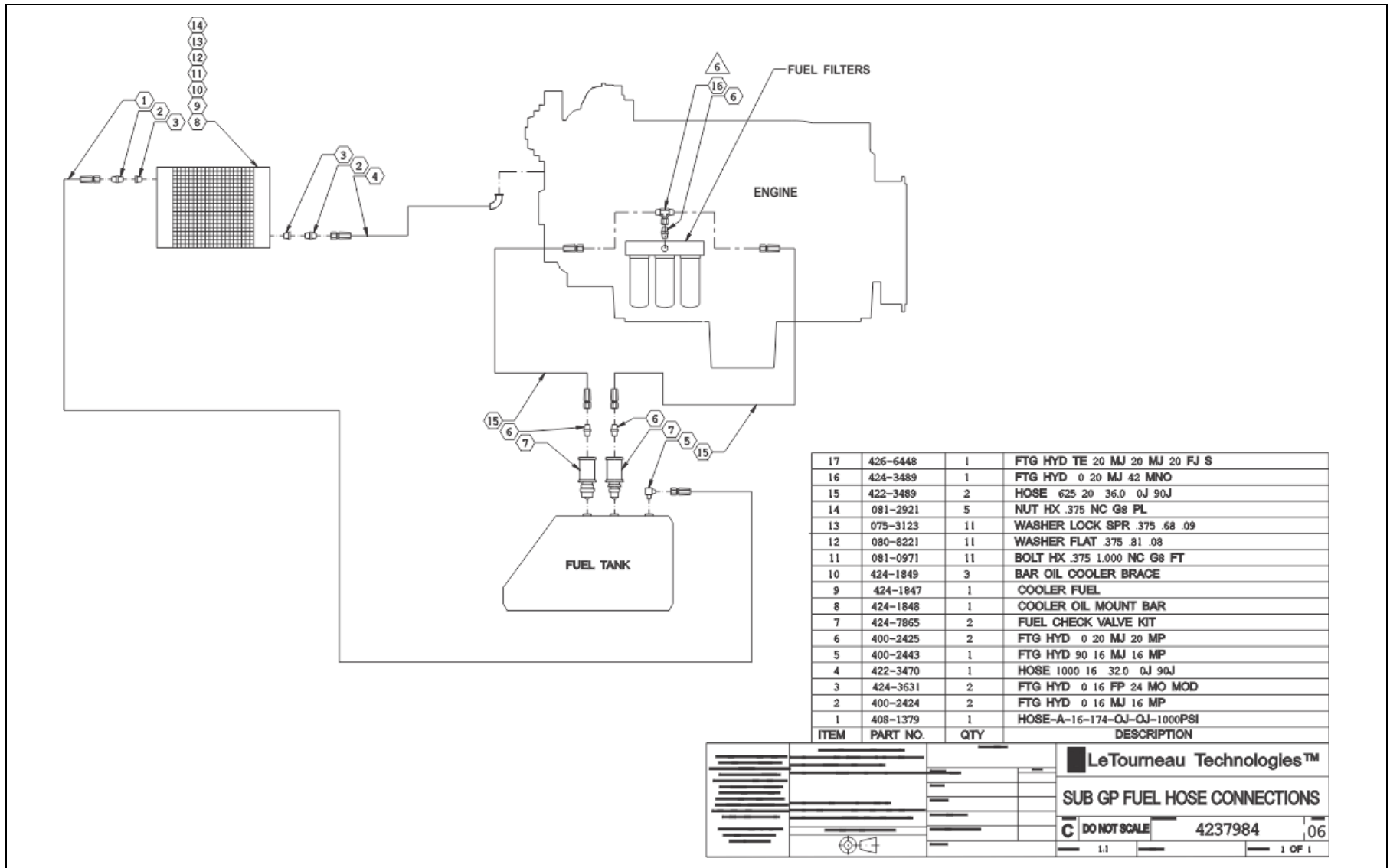

Figure 9. L-1850/L-2350 typical fuel system layout (Cummins)

This Page Intentionally Left Blank

Cooling System

NOTICE

In addition to these general instructions, it is **ESSENTIAL** to refer to the engine and radiator manufacturers' recommendations regarding proper maintenance of the cooling system and any special instructions they may provide in their operator manuals or service manuals.

Safety in Cooling System Maintenance

The following guidelines should be followed to ensure safety when performing service or repair operations to cooling systems:

WARNING

Crush hazards exist if the machine is started or moved while work processes are being performed on the machine. Place bucket flat and level on the ground. Place frame lock in the locked position and lock out the machine's starting capability before performing any work process. Follow all applicable lockout procedures and local rules and regulations for performing work processes. **ANYONE** performing inspections or service procedures to the machine should be familiar with **ALL** instructions and procedures contained in the machine's **SERVICE MANUAL**. Crush hazard could occur if the machine is started or moves while any type of work process is being conducted on the machine, resulting in serious injury or death.

- a. Wear a hard hat, protective glasses, and other protective equipment as required by job conditions.

WARNING



Burn hazard exists when working on or around hot cooling systems. Liquid cooling systems build up pressure, as the engine gets hot. Before removing the radiator cap, stop the engine and let the system cool. Remove the radiator cap or surge tank cap only after the coolant is cold. Failure to allow the coolant to cool can result in serious burns.



- 1) Shown in open position
- 2) To close
(located on top of rear frame)

Figure 10. Surge tank release ball valve

NOTICE

Turn ball valve to release pressure before removing the surge tank cap.

- b. Hot coolant and components can cause personal injury. Do not allow hot coolant or components to contact the skin.
- c. Be sure all guards and protective covers are in place and secure.



- d. DO NOT work on the machine with the engine running unless specifically instructed to do so by the engine manufacturer's operator's manual or service manual for the specific repair or maintenance that is to be completed.

Engine Exhaust Wrap

While running, and for some time after shutdown, the engine exhaust piping and muffler are hot enough to cause serious burns. Some machines are equipped with an engine exhaust wrap. The piping and muffler are wrapped with a material intended to help prevent burns. The wrapping should be checked daily to ensure it is secured properly.

CAUTION

Burn hazard exists if unwrapping the engine exhaust piping or muffler while hot. Wait for the engine exhaust to cool off before unwrapping the exhaust pipes for inspection. Failure to wait for the exhaust to cool off can cause burn hazards resulting in personal injury.

Troubleshooting

Cooling System

Overheating is the most common problem in cooling systems and can be avoided with proper maintenance. The most common causes of overheating are clogged systems, low coolant level, and defective water pumps and thermostats.

The most serious effect of overheating is the breakdown of engine lubrication. Engine overheating causes accelerated breakdown of the lubricating properties of the oil and causes formation of varnish. Warping and cracking of major engine components such as the cylinder head(s) and block is common in overheated engines and is made worse when followed by rapid cooling.

Corrosion

Restricted coolant flow as the result of the radiator becoming clogged with rust and scale is the most common cause of overheating. This problem can be prevented by regular rust proofing and cleaning when necessary.

As rust and scale forms on the walls of the engine water jacket and other metal parts, it flakes off and settles in the passages within the water jacket and in the tubes of the radiator. This cuts down on heat transfer and the result is engine overheating. Continual overheating causes the formation of more rust in the system that eventually results in the radiator becoming totally clogged.

Rust, scale, and grease can be removed by the use of double-action cleaners, which will not harm the system if used according to instructions. If rust and grease are not completely neutralized and flushed out, they can destroy the corrosion inhibitors in later fills of antifreeze and anti-rust solutions.

CAUTION

DO NOT use caustic cleaners in aluminum radiators, as the heat transfer surfaces will be damaged. BE SURE to verify that any cleaning solutions used are approved by both the engine and radiator manufacturer.

The entire system should be drained at least once a year. If the coolant has rust-colored appearance, a cooling system cleaning solution should be used. If no rust buildup is noticed, a radiator flushing solution or plain water should be used to thoroughly flush the entire system, including the block. Corrosion inhibitors will not clean out rust and scale already formed. Refill with a solution of antifreeze containing rust inhibitors sufficient to protect the system for the lowest possible temperatures expected.

CAUTION

Handling and disposal of used coolant may be subject to federal, state, and local laws and regulations. Use authorized waste disposal facilities for disposal of used coolant. DO NOT flush into municipal sewer systems or streams.

Coolant, Antifreeze and Rust Inhibitors

Minerals contained in the water from most municipal water systems are not desirable in engine cooling systems. Distilled water is recommended, but will still cause rust if used without a rust inhibitor.

Most radiators have an expansion volume built in and can be filled to the bottom of the filler neck. Refer to engine and radiator manufacturer's manuals for capacity and filling recommendations. A sight glass is provided on the surge tank, to monitor the coolant level.

Low silicate ethylene glycol based antifreeze is recommended as most diesel engines develop temperatures in excess of the boiling point of alcohol. Rust inhibitor should be added if the antifreeze does not already contain it.

NOTICE

A refractometer MUST be used to accurately measure the freeze point of coolant. DO NOT use a ball hydrometer. Floating ball hydrometers will give incorrect readings.

NOTICE

It is ESSENTIAL to use only as much antifreeze as is needed to protect the system from the lowest temperatures expected because with ethylene glycol-based antifreeze a mixture that is too strong can actually reduce the protection against freezing. Pure, undiluted antifreeze content or mixture will freeze at -10°F (-23°C). Beyond 70% antifreeze content or mixture, the freeze point reverts to the undiluted water freezing point.

CAUTION

NEVER pour hot water into a cold engine or cold water into a hot engine. This could crack the head or block.

Repair radiator and other cooling system leaks before adding antifreeze coolant.

CAUTION

DO NOT use radiator-sealing solutions to repair minor leaks without first confirming that they are approved by the engine and radiator manufacturer for use in the system. These solutions may not be compatible with water filters and alloys used in the components of the engine, radiator, and other parts. They can result in cooling system plugging and inadequate coolant flow that will cause overheating.

Supplemental Coolant Additives (SCA or DCA)

Heavy-duty diesel engines require a “heavy-duty coolant. Heavy-duty coolant is defined as a correct mixture of good quality water, low silicate antifreeze, and supplemental coolant additives (SCA or DCA). Supplemental coolant additives (or equivalent) are required to protect the cooling system from fouling, solder blooming, and general corrosion. A cooling system filter is required to protect the coolant system from abrasive materials, debris, and precipitated coolant additives. Engine manufacturers provide detailed instructions in their operators’ manuals on testing, concentrations, mixing, filters, and replacement cycles required for SCA or DCA. Some filters contain SCA or DCA in a unit number specified by the engine manufacturer. These additives completely dissolve in the coolant after two hours of operation. It is ESSENTIAL to refer to engine manufacturers’ manuals or authorized distributors and to follow their instructions.

NOTICE

A quick-connect fitting is optionally provided on the side of the engine for collecting coolant samples to verify DCA or SCA levels.

CAUTION

Insufficient concentration of the coolant additives will result in cylinder liner pitting and engine failure.

CAUTION

DO NOT use soluble oils in cooling systems. The use of soluble oils will cause cylinder pitting, corrode brass and copper materials, and damage heat transfer surfaces, seals, and hoses.

Radiator Inspection and Exterior Cleaning

The entire cooling system should be checked before any maintenance operations are begun.

- Check the radiator, water pump, hoses, drain cocks, block, and cylinder head(s) for leaks. Special attention should be given to checking the radiator for bent fins and tubes with cracks, kinks, dents, and split seams.
- The exterior of the radiator and hydraulic oil cooler should be inspected for an accumulation of dust and dirt as part of the operator’s daily walk-around inspection. The radiator and oil cooler should be cleaned with a hot-water high-pressure washer as required. Failure to keep the radiator and oil cooler coils clean could result in engine and hydraulic system overheating.
- The radiator should be periodically pressure tested per the manufacturer’s specifications. Any measurable drop in pressure may indicate an external or internal leak and should be thoroughly investigated and corrected.

NOTICE

Only experienced radiator repair technicians should make repairs to the radiator.

Radiator Cap

WARNING

Burn hazard exists if removing the radiator cap on a hot radiator. Wait for the coolant to cool before removing an engine radiator cap or engine coolant surge reservoir cap. Serious injury may result from escaping steam and hot coolant. On machines that utilize surge reservoirs, turn the ball valve to release the pressure before removing surge reservoir cap. Failure to wait for the coolant to cool can cause burn hazards resulting in serious burn injury.

Most radiator caps have a pressure valve to vent coolant or steam if pressure reaches a certain point, and a vacuum valve that opens to prevent vacuum in the cooling system. The radiator cap should be checked periodically with a pressure tester to be sure both valves are opening properly and at the pressures intended by the manufacturer. If either valve malfunctions, the cap should be replaced.

Leaks and Contamination

There are two kinds of leaks, external and internal. They can both cause engine overheating and contamination of the lubricating and cooling system resulting in costly repairs and downtime. It is essential to check the radiator coolant level and appearance during the operator's daily walk-around inspection. This is done by checking the sight glass on the top tank of the radiator or surge tank, as applicable. The surge tank cap should not be removed to check the coolant level.

External leaks: Most radiator leakage is the result of mechanical failure of soldered joints caused by cooling system pressure or engine or frame vibration. Other common locations for external leaks are hoses and hose connections, expansion or "freeze" plugs, gaskets, bolts, and capscrews. The cylinder block should be checked for coolant leakage both before and after it gets hot and while the engine is running.

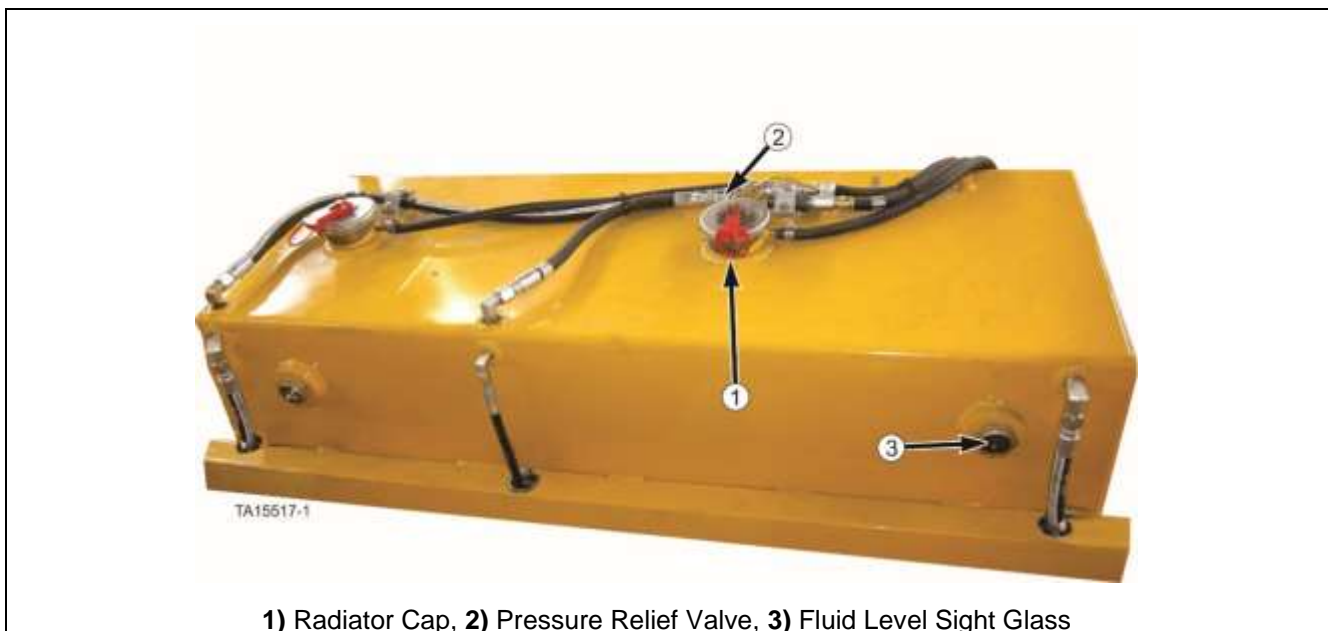

1) Radiator Cap, 2) Pressure Relief Valve, 3) Fluid Level Sight Glass

Figure 11. Radiator surge tank (typical view)

Testing the system with a pressure tester is a good method to locate an external leak.

Internal coolant leaks: Internal leaks have several reasons why they occur. Common internal leaks occur because of a loose cylinder head(s) or sleeve joint, defective gaskets, a cracked casting, or a malfunction in the pushrod compartment. Water or antifreeze will form sludge when mixed with engine oil. This will cause

lubrication failure, sticking piston rings and pins, sticking valves and valve lifters, and extensive engine damage. A milky appearance of the crankcase oil indicates an internal coolant leak.

NOTICE

Anytime an engine has overheated, it is recommended that the cooling system be pressure tested for leaks.

If an internal coolant leak is detected, the engine will have to be disassembled and the leak repaired properly before returning the machine to service. If replacing the cylinder head gaskets, be sure the head and block are checked for cracks and the mating surfaces are true, clean, and smooth. Follow the manufacturer's torque specifications and sequence for tightening cylinder head bolts.

Internal oil leaks: Contamination of the cooling system from an internal oil leak is also possible. One possible cause of such contamination is a cracked oil cooler core in some engines.

NOTICE

It is ESSENTIAL to follow engine manufacturer's instructions (available on manufacturer's website) regarding flushing of the cooling system to eliminate contamination resulting from an internal coolant or oil leak.

Thermostats

Faulty or improper thermostats can cause engines to warm up too slowly or to operate at the wrong temperatures.

CAUTION

ALWAYS use the thermostat recommended by the engine manufacturer. NEVER run an engine without thermostat protection (some engines have two or more).

Discard broken, faulty, or corroded thermostats. Do not use bellow-type thermostats in high-pressure cooling systems.

To check a thermostat, suspend it and a thermometer in a container of water and, while stirring, heat the water gradually. The thermostat should begin to open at the temperature stamped on it, plus or minus 10°, and should be fully open at 22° above the specified temperature. After removing the thermostat from the hot water, observe its closing action.

When installing a thermostat, clean the gasket surfaces and use a new gasket. Position the thermostat with the expansion element toward the engine (the frame should not block water flow).

Hoses

All hoses on the machine should be checked every 500 hours of operation for hardening, cracking, softening, and swelling. If hoses must be removed, check any inside reinforcing springs for corrosion.

Replace hoses often enough to be sure they are always pliable and able to pass coolant without leaking or shedding small particles of rubber, which could clog the radiator. Use only the best available hoses and coat connections with non-hardening sealing compound when installing. Tighten hose clamps securely. A pressurized cooling system can blow off an improperly installed hose.

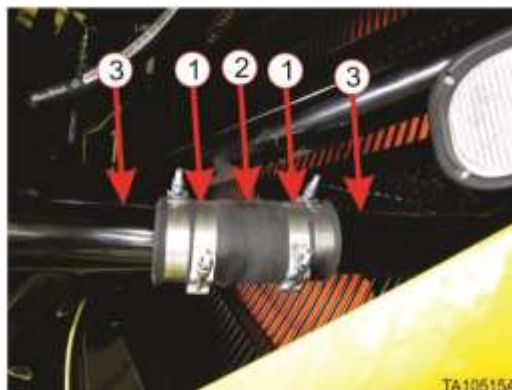

1) Clamp, 2) Hose, 3) Radiator Piping

Typical hose installation in radiator piping

Figure 12. Radiator piping hose installation (typical)

NOTICE

The photographs in illustration above show typical hose installations in the radiator piping. These hose installations appear at multiple locations. It is essential to inspect the hose installations every 500 hours of operation for hardening, swelling, cracking, or softening. Inspect clamps to ensure they are secure and properly positioned. An illustration of the radiator piping for specific machines is provided in the PARTS MANUAL.

Water Pump

Overheating can quickly occur if the water pump malfunctions. Pump malfunctions may be caused by leaks in the housing, broken or bent vanes on the impeller, and damaged seals or bearings.

NOTICE

If a pump must be removed and disassembled for inspection, replace all damaged or worn parts and use new seals and gaskets when reassembling. Follow the manufacturer's instruction.

Filters

Some engines have filters in the cooling system. The filter element and resistor plates may contain chemicals that remove or neutralize corrosives. These chemicals alkalize the coolant enough to prevent corrosion of metal parts and to form rustproof films on metal surfaces.

NOTICE

If the engine is equipped with a coolant filtration system, it is **ESSENTIAL** to follow manufacturer's instructions for replacing the water filter and draining water from the lower sump of the filtration system.



1) Coolant Conditioning Filters
(Mounted at top – front of engine - Cummins engine shown)

Figure 13. Typical coolant conditioning filters

Accessory Drive Belts and Fan Service

The drive belts should be periodically checked for signs of early failure, i.e. cracks, splits, excessive stretching, and fraying. Replace belts when these signs are present. Adjust belt tension as specified by the engine manufacturer. Too much tension causes premature failure of the belt and bearings. Too little tension permits belt slippage and causes insufficient cooling and excessive belt wear. Worn pulleys should be replaced when manufacturer's limits are reached.

Fan service usually consists of making sure the blades are straight and far enough from the radiator so they will not strike the core.

Aeration

Aeration is caused by air inside a cooling system mixing with the coolant. It can accelerate the formation of rust and corrosion and it can cause foaming, overheating, and loss of coolant through the overflow pipe. Aeration may result from a leak in the system, turbulence in the top tank, and too low coolant level.

Use the following steps to check for aeration in the cooling system:

- a. Adjust coolant to proper level.

- b. Replace pressure cap with plain but airtight cap.
- c. Attach rubber tube to lower end of overflow pipe.
- d. With machine parked, run engine at high throttle until temperature gauge stops rising and stabilizes.
- e. Without changing engine speed or temperature, place the end of the rubber tube in a container of water.
- f. A continuous stream of bubbles from the tube will show that air is being drawn into the cooling system.

NOTICE

All Komatsu installed power units are approved for proper de-aeration capabilities. Flange and hose routing should never be altered without factory approval.

Exhaust Gas Leakage

Exhaust gas can enter the cooling system through a crack in the cylinder head or a loose cylinder head joint even though the joint may be tight enough to keep liquid from leaking into a cylinder. Exhaust gases dissolved in the coolant will destroy the rust inhibitors and form acids that cause corrosion, rust and clogging. The cylinder head(s) gasket(s) may burn or corrode because of the gases and excess pressure may force coolant out of the overflow pipe.

Exhaust gas leakage can cause the coolant to be rusty or cause severe rust clogging, corrosion, or overflow losses. A chemical tester is available to detect the presence of exhaust gas in the cooling system. It should only be used by experienced personnel, as its use requires opening the radiator.

Flushing the Cooling System

The cooling system should be flushed and thoroughly checked at least once a year and always before installing new antifreeze. Incomplete flushing, such as hosing out the radiator, will close the thermostat and prevent thorough back flushing of the block.

Flushing Procedures

- a. Drain the coolant from the radiator and engine.
- b. Refill with soft, clean water. If rust is present, the use of a chemical cleaning solution may be required to achieve the desired results. Refer to engine and radiator manufacturer owner's manuals for recommended cleaning solutions. If the engine is hot, fill slowly to prevent rapid cooling and distortion of engine castings.
- c. Start the engine and operate it for fifteen minutes to circulate the water thoroughly.
- d. After thoroughly flushing the system, open all drain points to drain the system.
- e. Clean out the overflow pipe; remove insects, dirt, and any other foreign matter from the radiator passages, radiator grille, and screens.
- f. Check the thermostat, radiator pressure cap, and the cap seat for dirt and corrosion.
- g. Refill with the proper mixture of antifreeze to protect the system down to the lowest possible temperature expected.

CAUTION

Filling the radiator at over 5 U.S. gallons (20 liters) per minute can cause air pockets to form in the cooling system.

NOTICE

Refilling the cooling system can be best accomplished by using the optional (refer to illustration "Central service system (opt.)," below).



Figure 14. Central service system (opt.)

- h. After draining and refilling the cooling system, ALWAYS operate the engine with the radiator cap removed until the coolant level stabilizes.
- i. Recheck the coolant level and add coolant as necessary to fill the system. The system should be filled to a point midway between the radiator core and the bottom of the filler neck to allow for expansion.

Cooling systems can also be pressure flushed and reverse flushed. Refer to the engine manufacturer's operator's manual and service manual for recommendations and instructions on performing these procedures.

If the radiator cannot be satisfactorily cleaned by normal flushing with the aid of chemical cleaners, reverse or pressure flushing, it may be necessary to remove the upper tank and rod out the radiator tubes. Only qualified and experienced personnel should perform this operation.

Cooling System External Monitoring

The cooling system is monitored by the LINCS computer system. Should the engine overheat, the RED alarm light will illuminate, an audible alarm will sound and an ALARM screen indicating engine overheating will appear on the computer monitor. Traction will be inhibited and the machine will go into dynamic braking, which will stop the machine. **Should an alarm situation occur, SHUT THE ENGINE DOWN IMMEDIATELY. Serious engine damage could occur during an alarm situation if the engine is not shut down immediately.**

The operator can silence the audible alarm and remove the ALARM message from the computer monitor; however, the RED alarm light will continue to illuminate and the fault will be logged into the VIEW ACTIVE ALARMS option of the Maintenance Menu. The light can be turned off and the fault removed from the log, only by maintenance personnel who have access to the service function of the LINCS computer system.

Engine Air Restriction Gauges

The engine safety filters are monitored by two “Engine Air Restriction Indicators”. They are located inside a box assembly, mounted above the generator/below the KLENZ™ box.

These indicator restriction gauges provide both a visual monitoring point and an indication of restriction signal for the machine’s onboard monitoring/control system (LINCS). The indicator restriction gauge visually shows an indication of restriction in inches of water.

After new filters are installed, a clean filter reading of approximately 12” (304 mm) H2O for Detroit engine and 15” (381 mm) H2O for Cummins engine is typical. If the engine filters restriction reaches 20” (508 mm) H2O, the restriction gauge has an internal switch that actuates, causing LINCS to generate a Red Alarm and send the engine into a timed shutdown sequence. A reset button is located on the bottom of each restriction gauge.



Some machines have two and some have four restriction gauges, depending on engine manufacturer

Figure 15. Engine filter restriction gauges

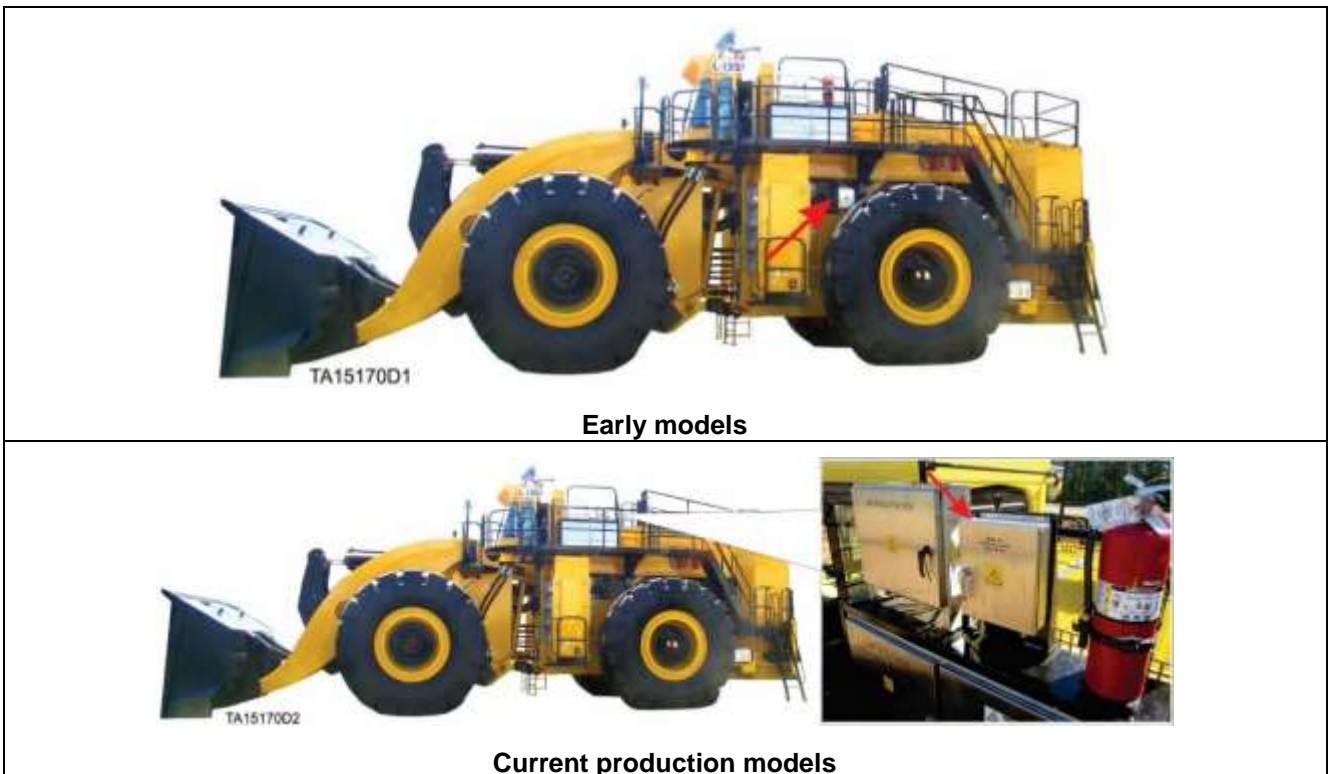

Early models

Current production models

Figure 16. Engine filter restriction gauge location

The air restriction gauges must be reset after the filters are replaced. Press the reset button to cause the indicator to return to original position.

NOTICE

KLENZ™ filters should NEVER be cleaned and reused. Always replace filters with the correct Komatsu replacement filters.



Figure 17. Reset button located on bottom of restriction gauge

Engine Safety Adapter

The safety adapter is located between the restriction gauge intake hose and the KLENZ™ box structure engine intake tubing flange (typically threaded into the engine intake tubing flange). One restriction adapter is located on each engine filter turbo tube flange. Restriction of the adapter can prevent the engine safety filter alarm from alarming.



Figure 18. Engine filter safety adapter location

Engine Exhaust Stacks Guard Assembly

The engine exhaust stacks may have an optional guard assembly surrounding them, to help prevent burns when working in close proximity while they are hot.

CAUTION

Burs and fall hazards exist if working around the engine exhaust stacks while they are hot. The ends of the stacks extend outside the guard assembly and can be physically touched. Touching the stacks while hot can produce severe burns. Personal injury from burns, or reacting to burns and falling, is possible. Always wear personal protective equipment (PPE) to prevent burns. Failure to avoid touching the stacks can cause burn and fall hazards resulting in injury.



Figure 19. Engine exhaust stacks guard assembly

Vendor Literature

VL124 – L&M Mesabi Service Manual for Oil Cooler

VL125 – L&M Mesabi Service Manual for Radiator

VL132 – Mesabi Service Manual for Copper Tube

This Page Intentionally Left Blank

SERVICE MANUAL



HIGH EFFICIENCY COPPER TUBE AIR-TO-OIL & AIR-TO-AIR COOLERS

MAXIMUM 150 PSI (1034 KPA)

Please read and follow instructions carefully before proceeding with any service work and/or repairs. Consult factory before proceeding with any possible warranty claims.

CONTENTS

MESABI® High Efficiency Copper Tube Air-to-Oil and Air-to-Air Cooler

Warranty	Page 2
Standard Parts & Tools	Page 3
Standard External Cleaning	Page 4
Epoxy-Coated Core External Cleaning	Page 4
Internal Cleaning	Page 4
Tube Removal	Pages 4 & 5
Seal Installation	Page 5
Cleaning Tube Ends	Page 5
Lubrication	Page 5
Tube Installation	Pages 6 & 7
Pressure Testing	Page 7
Manufacturing & Parts Facilities	Page 8

This service manual is available to print online at www.MESABI.com. A service video is also available for viewing online, or request a DVD from L&M Radiator. The service video does not replace the information contained in this service manual.

CONTACT L&M'S CUSTOMER SERVICE DEPARTMENT PRIOR TO REPAIRS WHERE WARRANTY CLAIM IS A POSSIBILITY. FAILURE TO DO SO MAY VOID WARRANTY.

L&M RADIATOR GENERAL WARRANTY

Consult L&M before proceeding with warranty claims or repairs. Failure to do so may void this limited warranty. This limited warranty allocates the risk of failure of the product(s) between the buyer and L&M and is reflected in the purchase price.

L&M warrants that MESABI® products will conform to L&M's written quotation specifications and drawings. MESABI® framework components are warranted for 18 months from the date of invoice against defects in materials and workmanship during normal usage. L&M warranty against seal leakage during normal operation is stated in individual product literature.

L&M's liability is limited to the rework or replacement (at L&M's sole option) of products or parts manufactured by L&M that are determined by L&M to be defective in workmanship or material or do not meet L&M's quoted specifications.

L&M product warranty does not apply if the product has been subjected to abnormal use or conditions, unauthorized modifications or repair, corrosion, misuse, neglect, abuse, accident, improper installation, or other acts which are not the fault of L&M, including damage caused by shipping.

L&M does not warranty products incorporated into L&M products that are not manufactured by L&M. Buyer's sole recourse with respect to such products will be subject to the warranty of the individual manufacturer.

OTHER THAN AS STATED HEREIN, L&M MAKES NO REPRESENTATION OR WARRANTY OF ANY KIND, EXPRESSED OR IMPLIED, AS TO MERCHANTABILITY OR FITNESS FOR A PARTICULAR PURPOSE, OR ANY OTHER MATTERS WITH RESPECT TO THE SALE OF L&M PRODUCT(S) AND ALL IMPLIED WARRANTIES OF MERCHANTABILITY OR FITNESS FOR A PARTICULAR PURPOSE ARE HEREBY DISCLAIMED. IN NO EVENT WILL L&M'S LIABILITY INCLUDE ANY SPECIAL, INCIDENTAL, CONSEQUENTIAL OR PUNITIVE DAMAGES, EVEN IF L&M KNEW OF THE LIKELIHOOD OF SUCH DAMAGES.

Any action or lawsuit for breach of the limited warranty in these L&M terms and conditions must be commenced in Minnesota. This warranty supersedes all previously published warranties.

MESABI® PRODUCT SPECIFIC WARRANTY COPPER TUBE AIR-TO-OIL AND AIR-TO-AIR COOLER

MESABI® Copper Tube Coolers are covered by the L&M General Warranty along with the following Product Specific Warranty:

L&M Radiator warrants MESABI® Copper Tube Coolers against seal leakage during normal operation for 48 months from date of invoice on new coolers.

MESABI® High Efficiency Copper Tube Air-to-Oil and Air-to-Air Cooler

STANDARD PARTS

Exploded view of a typical MESABI® High Efficiency Copper Tube Air-to-Oil and Air-to-Air Cooler

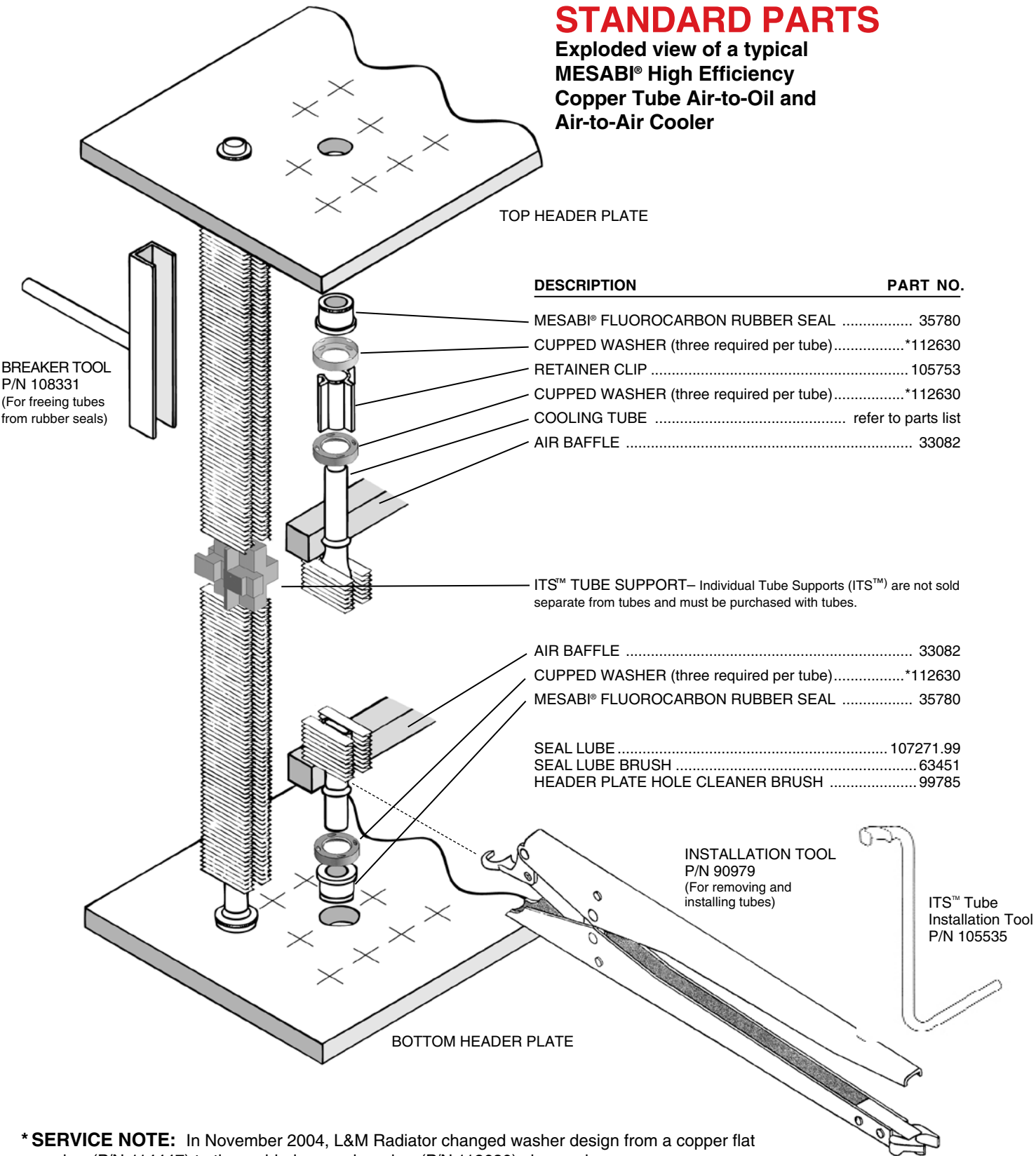

DESCRIPTION	PART NO.
MESABI® FLUOROCARBON RUBBER SEAL	35780
CUPPED WASHER (three required per tube).....	*112630
RETAINER CLIP	105753
CUPPED WASHER (three required per tube).....	*112630
COOLING TUBE	refer to parts list
AIR BAFFLE	33082
ITS™ TUBE SUPPORT– Individual Tube Supports (ITS™) are not sold separate from tubes and must be purchased with tubes.	
AIR BAFFLE	33082
CUPPED WASHER (three required per tube).....	*112630
MESABI® FLUOROCARBON RUBBER SEAL	35780
SEAL LUBE	107271.99
SEAL LUBE BRUSH	63451
HEADER PLATE HOLE CLEANER BRUSH	99785

*** SERVICE NOTE:** In November 2004, L&M Radiator changed washer design from a copper flat washer (P/N 114447) to the molded cupped washer (P/N 112630) shown above. These parts are completely interchangeable. PART NO. 114447 MAY STILL BE USED IN HIGH TEMPERATURE APPLICATIONS. CONTACT L&M FOR DETAILS.

Cleaning

Standard External Cleaning

To assure maximum life of a MESABI® Core, reasonable care must be taken when cleaning.

Most radiator shops use a hot alkaline soap, caustic soda or chemical additives in their boil-out tanks, which attacks solders. If a MESABI® tube is soaked in such a solution, the solder bond between the finning and tube will be adversely affected. It must be known that the solution used is not harmful to solder so that it will not attack the solder used on the MESABI® tube. Be sure to completely rinse the cleaned tube/core in clean water after removing from the boil-out tank.

In most cases, it may be best to blow out any dry dirt with a high-pressure air gun prior to washing core with the high-pressure, hot-water washer.

For general external cleaning, a high-pressure, hot-water washer (with or without soap) can be used at pressures up to 1200 psi (8268 kPa). **(CAUTION! To prevent fin damage, stay a few inches away from the core and you must spray straight into the core – not at an angle.)**

If the cooler is still in the machine, you may have to use an offset angled nozzle so that you can spray straight into the core. If there is any doubt, try your cleaning method on a small portion of the core first.) It is important to start on the air exit side. Work from the top to the bottom. Concentrate on small areas and work slowly. Wash until the water exiting the opposite side is free from dirt and debris. Complete this side and then repeat the process from the other side.

Epoxy-Coated Core External Cleaning

Epoxy-coated cores must be cleaned with care to ensure the coating is not damaged.

1. A high-pressure, hot-water washer can normally be used. Use a “fresh” water supply. Water temperature should not exceed 180° F (82.2° C). Do not steam clean. The nozzle should be kept approximately 12 inches (30.48 cm) away from the core.

CAUTION: We do not recommend a pressure rating because as epoxy ages the coating becomes brittle and might be damaged at higher pressures. We recommend that you try your cleaning method on a portion of a single tube first.

2. Wash the core thoroughly and methodically, starting at the top and working towards the bottom. Do not wash in one area for extended periods. The core will be clean when the water exiting the core is clean.
3. Blow off excess water with air. Epoxy coatings are not meant for submerged duty. L&M Radiator does not warrant against corrosion, but this coating, properly cared for, will help increase the service life and efficiency of your cooling system.

Internal Cleaning

The MESABI® copper tube coolers have an internal stainless steel turbulator that **CANNOT** be removed from the tube. In cases where it is necessary to clean the inside of the cooler, before removing any tubes or pumping any chemicals through the cooler, contact L&M Customer Service. See back page for contact information.

Tube Removal

HELPFUL HINTS:

- If all tubes are to be removed, pull out the air baffle prior to washing the core.
- Clean the core prior to removing tubes.
- To avoid bending or kinking tube ends, reduce the angle of the tube as it is being pulled from the top seal.
- If the core has a center tank, remove the top core tubes and seals first.
- If the core has an ITS™ (Individual Tube Support) system, mark the bars front and back before removing to ease re-assembly. Also note the position of the front tabs on the ITS™ – tubes support relative to the face of the cooler.
- To assist in the removal process, spray light oil on the top end of the tubes.
- If tubes are difficult to remove, try using the breaker tool and removal tool simultaneously.



Fig. 1

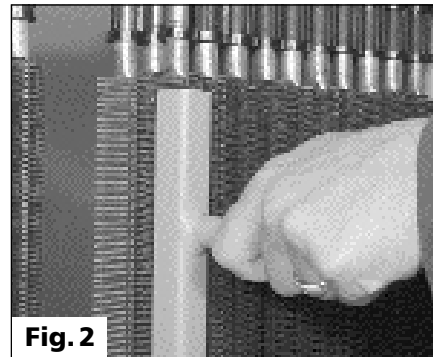

Fig. 2

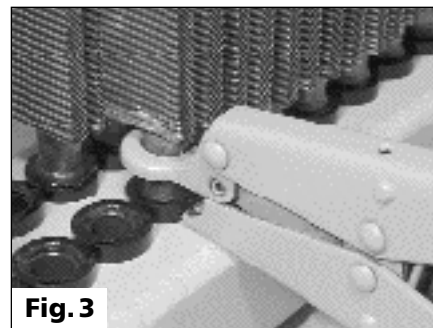

Fig. 3

STEP 1.

Use a pair of pliers to remove the retainer clip from the top of the tube, as shown in **Fig. 1**.

STEP 2.

Loosen the tube by using Breaker Tool L&M P/N 108331, as shown in **Fig. 2**. The Breaker Tool should be placed at top or bottom, not at middle, when freeing tube from seal. Lightly twist the tube back and forth, to loosen tube from seals.

STEP 3.

After tube is free, place upper jaw of Installation Tool, L&M P/N 90979, around the round portion at the bottom end of tube. Place lower jaw so that it rests on the header plate, just in front of the rubber seal, as shown in **Fig.3. DO NOT allow the lower jaw to rest on the washer.**

Squeeze handles of tool together and raise tube up as far as possible.

Tube Removal (continued)

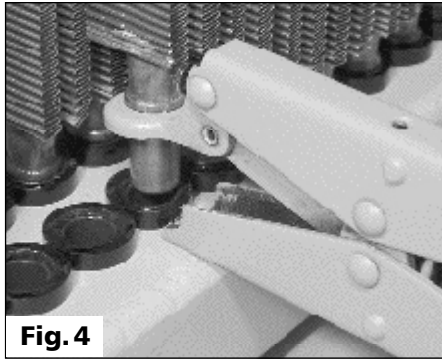

STEP 4.

Reposition tool, so the upper jaw is between the upset on the tube and the cupped washer as shown in **Fig. 4**. Raise tube until bottom end clears the washer and seal.

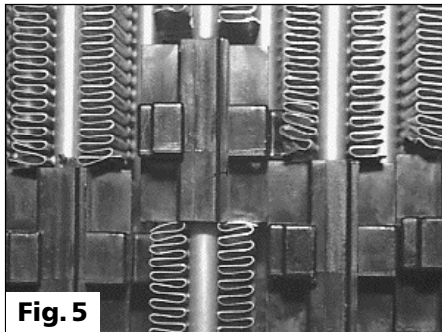

If you are working with an ITS™ core, the tube should be raised high enough so that the interlocking tab clears the adjacent dovetail groove as shown in **Fig. 5**. **Raising a second tube will help the removal process on simple repairs.**

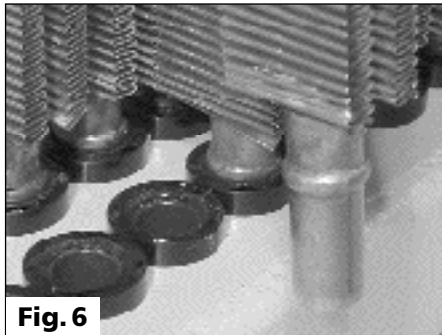

STEP 5.

Use a minimum of angle to swing the tube out, just far enough to allow it to be pulled down and out of its top seal, as shown in **Fig. 6**.

Cleaning Tube Ends

Before the original tubes are reinstalled, the tube ends must be clean of foreign material. L&M recommends polishing the tube ends with a polishing wheel (Grainger #5A725 – use Qty. 5 together) and a copper polishing compound (Grainger #3W769).

If the debris cannot be removed by polishing, L&M recommends using a piece of fine grit emery cloth or steel wool. If there is a lot of debris on the tube ends, use a 6 in. or 8 in. (15.24 cm or 20.32 cm) diameter wire wheel brush with a wire size of .006 in. or .008 in. (.152 mm or .203 mm). Larger diameter wire sizes could damage the tube ends. Try installing a tube. If it does not slide easily into the top and bottom seals, try polishing the tube ends as per above.

Seal Installation

HELPFUL HINTS:

- L&M recommends installing new MESABI® seals any time tubes are removed.
- After removing the old seals, clean the plate holes of any foreign debris. We recommend using L&M P/N 99785 header plate hole cleaning brush in an electric or air drill.
- Clean inside of tanks and blow out plate holes with air.
- **Install new seals in clean, dry holes.**
- If the core has a center tank, do not install seals at the bottom of the top core until all the tubes are installed in the bottom core.

With your thumb start the new MESABI® seals into the holes and push them part way in. Care must be taken not to install seals too far into the header plate.

The use of a hammer directly on the seal can easily cause seals to be installed too far into the header plate. L&M recommends the use of a flat plate, 3/8 in. x 3 in. x 6 in. (9.53 mm x 76.20 mm 152.40 mm), placed over the seals and hitting with a rubber mallet will allow the seals to be properly installed.

A properly installed seal has a crowned or convex top surface, and the tube hole is slightly flared at the opening. A seal that is installed too far into the header has a concave top surface and the tube hole is noticeably smaller in diameter as shown in **Fig. 7**. **Seals installed too far will make tube installation more difficult and are much more likely to be damaged during tube installation.**

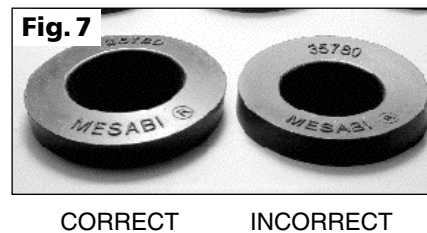

ON THE LEFT:
Properly installed
P/N 35780 seal.

RIGHT:
P/N 35780 seal
installed too far into
header (concave).

Cupped Washer Installation – After the seals have been installed, place the cupped washers P/N 112630 over the seals. The washers should be pressed firmly onto the seal so that they encompass the seal flange. **If you are servicing with the old style flat copper washers see service note, page 3.**

Seal Lubrication – After all the cupped washers are in place, lubricate all the seals. Use L&M lube brush P/N 63451 and assembly lube P/N 107271.99.

Tube End Lubrication – It is important to visually inspect both ends of each tube for damage prior to lubrication. Correct any problems or replace tubes. Lubricate both ends of each tube using the 63451 lube brush and 107271.99 lubricant.

Tube Installation

HELPFUL HINTS:

- If you are working with a center tank core, the bottom core must be assembled before the top core. **DO NOT install seals at the bottom of the top core (top side of the center tank).**
- Minimize the angle of the tube as it's being installed into the top seal.
- Make sure the tube is centered in the bottom seal before any force is applied to pull or push into place.

A vertical cooler position with the bottom header of the section being worked on at a comfortable height for the assembler is recommended.

CAUTION! If a tube seems difficult to install into a seal, STOP and figure out WHY! One of the following reasons could be the answer.

1. A tube or seal has inadequate lubrication.
2. Seal improperly installed (may be pushed too far into the header plate hole).
3. Damaged tube end.
4. Trying to insert the tube into the seal at too steep of an angle.
5. Tube is not centered in seal.

NOTE: If for any of the above reasons a tube is difficult to install, the seal should be removed and inspected for any scuffing marks, tears or cuts. If there is any doubt, replace the seal.

Recommended Tube Installation Pattern:

- It is recommended that tubes be installed outwardly from each side member or tension tie across all rows in a "diagonal pattern" as indicated in the sketch. This pattern will provide better control of the tube and allows a 100% view of the seal during tube installation and seal inspection.
- The diagonal pattern should be continued until there is not enough room at which point the centermost row should then be completed, followed by the remaining rows.
- The diagonal pattern can slope right or left, but each tube installed should be the outermost tube compared to adjacent rows to allow for the best grip on the tube and maximum visibility of the washers and seals.

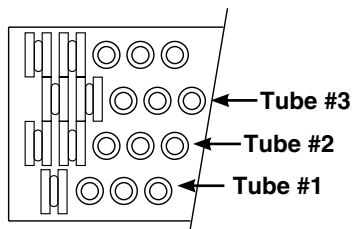

Air baffles can be pulled into place using a heavy string or a wire after final pressure testing. Air baffles are not required behind gussets. Before the last tube is installed in the outside row adjacent the air baffle, a wire or heavy string can be installed where the air baffle is required.

ITS™ - Individual Tube Support Installation

Make sure the tabs on the ITS™ tube supports are facing to the front and to the right.

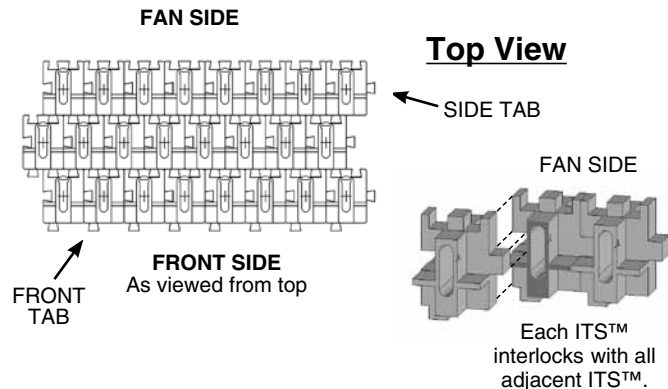

STEP 1. Before installing tubes, place one cupped washer P/N 112630 on the top end of each tube making sure that the flat face of the washer faces upward towards the top of the tube. This will allow the retainer clip P/N 105753 to slide into position properly. (see page 3).

STEP 2. Installing the tube in the top seal:

Carefully insert the tube into the top seal. The cupped washer will help keep the tube centered in the top seal. Keeping the tube at a minimum angle, with a slight twisting forward motion, push the tube into the seal far enough to clear the bottom washer/seal. To minimize installation angle, tubes in any given row should be installed from the closest header edge.

STEP 3. Installing the tube in the bottom seal:

Hold the tube with one hand near the center of the tube (above the ITS™ if there is one present) and the other hand near the bottom end of the tube.

- Holding the tube at the center allows you to easily deflect the tube sideways enough to allow a full grip on the tube with your upper hand and eliminate any interference when ITS™ systems are used.
- Holding the tube close to the bottom provides the best control of the tube end and lowest force on both hands.

Looking below your lower hand to see the washer/seal, slowly insert the tube about 1/4 to 3/8 inch (6.35 mm to 9.53 mm) into the bottom seal.

NOTE: When ITS™ systems are present, there is no need to worry about engaging the ITS™ until the tube is 1/4 to 3/8 of an inch (6.35 mm to 9.53 mm) into the bottom seal.

STEP 4. Fully seat the tube into the bottom seal, engaging the ITS™ when present. Tool P/N 105535 can be used at this point to help pull the tube into the bottom plate. Tool is positioned at top of tube as shown in **Fig. 8**.

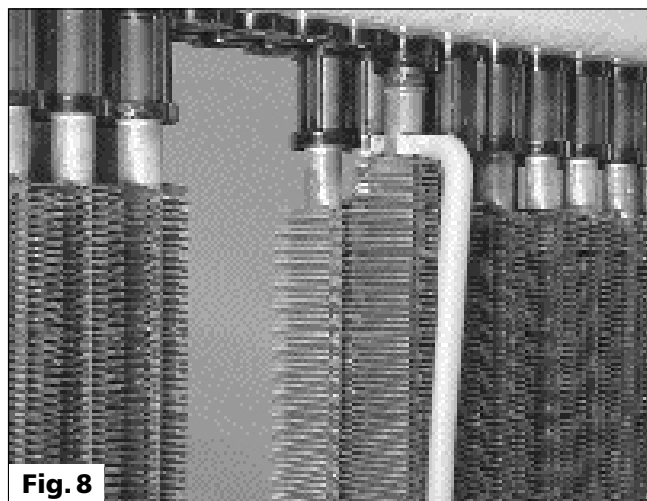

STEP 5. Using a pair of pliers, reinstall the tube retainer clips P/N 105753 on the inner rows of tubes positioning the center tab towards the front of the cooler. The retainers on the outermost (front) row of tubes can be installed after all the tubes are in place. **See Fig. 9** for proper positioning of the retainer clips.

NOTE: The tabs on our older style retainer clips, P/N 33567 are wider and must be rotated slightly so that they overlap.

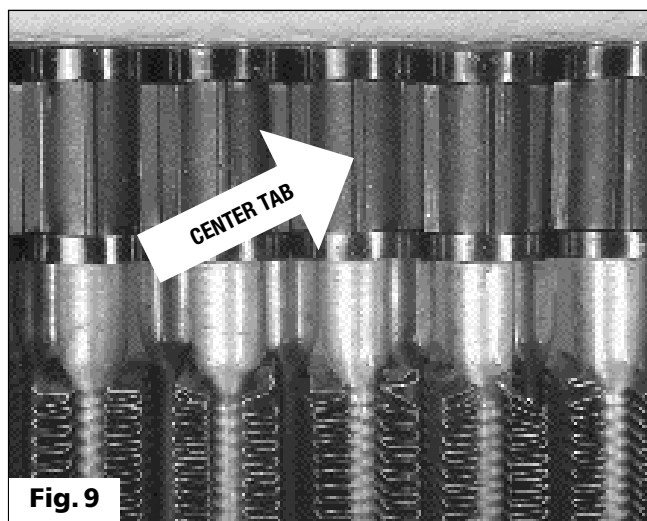

Picture shows retainer clips in place with center tabs facing outwards towards the front of the cooler.

STEP 6. Repeat the previous steps for the subsequent diagonal groups of tubes.

STEP 7. (If applicable)
If you are working with the ITS™ support system, install the appropriate support bar as shown in **Fig. 10**.

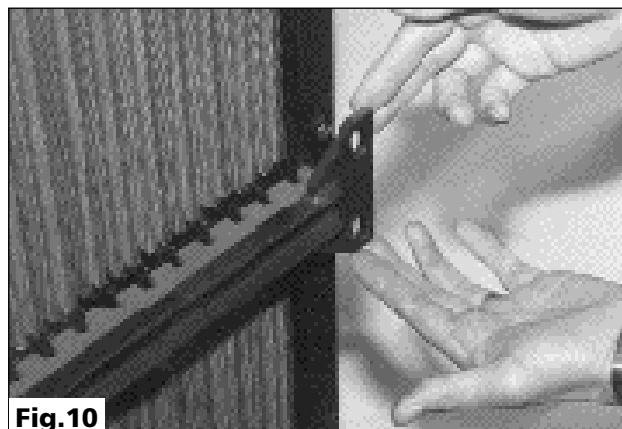

The support bar part number has been stamped on the outside face. Use the L&M Radiator Assembly Drawing and Parts List (on page 3) for proper installation. Using a rubber mallet, gently tap the bar into place and secure to the side member with bolts.

STEP 8. The air baffles can be installed after pressure testing as indicated earlier.

Pressure Testing

Pressure testing procedure that follows recommends testing to 150 psi (1034 kPa). You should test to pressure rating specified on tag attached to your cooler. If there is no pressure rating specified, please contact L&M Customer Service with the part number of your cooler.

Caution: Always bring pressure up slowly and use personal protection gear. Tube retainer and support bars (if applicable), must be installed prior to testing.

1. Install fittings or cover plates in or over all ports. One port to have an air supply connector.
2. Pressurize with line pressure not exceeding 150 psi (1034 kPa) and submerge in water. Repair or tighten fittings to eliminate leaking. Note that air bubbles from trapped air in exterior pockets could appear for 10 to 15 minutes. This is normal. Repeat as needed until no leaks are detected.
3. After successful pre-testing to find and repair major leaks, cycle testing can begin. Pressurize with compressed air or nitrogen to 150 psi (1034 kPa) and hold submerged for 15 minutes. Repair any leaks that occur and repeat until you have reached a 15 minute time period successfully. Then cycle to 0 psi and pressure back to 150 psi (1034 kPa) and hold for 1 minute. Repeat this process three more times and hold the last cycle for 5 minutes. After any repairs in this stage, start the cycling testing over from the beginning until you have a successful test.

• If you have any questions regarding the procedures described in this Service Manual, please contact L&M Radiator and ask for Customer Service. See back page for contact information.

• All information, illustrations and specifications in this Service Manual are based on the latest information at the time of publication or posting online at www.MESABI.com. The right is reserved to make changes at any time without notice.

MESABI[®] heat exchangers are the world standard for heat exchanger reliability



L&M RADIATOR FACTORY-DIRECT SALES AND SERVICE

Because so many of our radiators and heat exchangers are a custom design, all sales are on a factory-direct basis. This assures that our customers receive a product that meets their cooling/heating requirements, offered to them at the least possible price.

We ship most parts within 24 hours. On-site technical and engineering assistance is available almost anywhere in the world within a few days notice.



L&M QUALITY POLICY

"The Quality Policy of L&M Radiator is to produce a quality engineered, quality manufactured product through continuous improvement that we deliver to the customer's satisfaction."



Manufactured and distributed by:

Toll Free: 800-346-3500 (U.S.A. and Canada)
Web Site: MESABI.com Email: cool@MESABI.com

WORLD HEADQUARTERS

L&M Radiator, Inc.
1414 East 37th Street
Hibbing, Minnesota 55746 U.S.A.
Telephone: (218) 263-8993
Fax: (218) 263-8234

ISO 9001:2008
CERTIFIED

UNITED STATES



L&M Radiator, Inc.
Hibbing, Minnesota U.S.A.



L&M Radiator, Inc.
Independence, Iowa U.S.A.



L&M Radiator, Inc.
El Paso, Texas U.S.A.



L&M Radiator, Inc.
Yankton, South Dakota U.S.A.

MEXICO



L y M de Mexico S.A. de C.V.
Calle De La Plata y Los Nogales
Parque Industrial
Hermosillo, Sonora, Mexico
Telephone: 011-52-662-251-0480
Fax: 011-52-662-251-0638
Email: ventas@lym.com.mx

AUSTRALIA



L&M Radiator Pty. Ltd.
Cnr. Kew & Kathleen Streets
Welshpool, Western Australia 6016
Telephone: +61-8-93616855
Fax: +61-8-94703075
Email: cool@mesabi.com.au

MESABI[®] is a registered trademark of L&M Radiator, Inc.
ITS[™] is a trademark of L&M Radiator, Inc. Copyright © 2010 L&M Radiator, Inc.

SERVICE MANUAL

MESABI®

COPPER TUBE

- **RADIATORS**
- **CORES**
- **AIR-TO-AIR COOLERS**
- **LOW PRESSURE OIL COOLERS & FUEL COOLERS (MAXIMUM 50 PSI/345 KPA)**

Please read and follow instructions carefully before proceeding with any service work and/or repairs. Consult factory before proceeding with any possible warranty claims.

CONTENTS

MESABI® Radiator Cores

Warranty	Page 2
Standard Parts & Tools	Page 3
External Cleaning	Page 4
Epoxy Coated Core External Cleaning	Page 4
Internal Cleaning	Page 4
Removing Tubes	Pages 4 & 5
Cleaning Tube Ends	Page 5
Installing Seals	Page 5
Lubrication	Page 5
Installing Tubes	Pages 6 & 7
Pressure Testing	Page 7
Manufacturing & Parts Facilities	Page 8

CONTACT L&M'S CUSTOMER SERVICE DEPARTMENT PRIOR TO REPAIRS WHERE WARRANTY CLAIM IS A POSSIBILITY. FAILURE TO DO SO MAY VOID WARRANTY.

MESABI® GENERAL WARRANTY

Consult L&M before proceeding with warranty claims or repairs. Failure to do so may void this limited warranty. This limited warranty allocates the risk of failure of the product(s) between the buyer and L&M and is reflected in the purchase price.

L&M warrants that MESABI® products will conform to L&M's written quotation specifications and drawings. MESABI® framework components are warranted for 18 months from the date of invoice against defects in materials and workmanship during normal usage. L&M warranty against seal leakage during normal operation is stated in individual product literature.

L&M's liability is limited to the rework or replacement (at L&M's sole option) of products or parts manufactured by L&M that are determined by L&M to be defective in workmanship or material or do not meet L&M's quoted specifications.

L&M product warranty does not apply if the product has been subjected to abnormal use or conditions, unauthorized modifications or repair, corrosion, misuse, neglect, abuse, accident, improper installation, or other acts which are not the fault of L&M, including damage caused by shipping.

L&M does not warranty products incorporated into L&M products that are not manufactured by L&M. Buyer's sole recourse with respect to such products will be subject to the warranty of the individual manufacturer.

OTHER THAN AS STATED HEREIN, L&M MAKES NO REPRESENTATION OR WARRANTY OF ANY KIND, EXPRESSED OR IMPLIED, AS TO MERCHANTABILITY OR FITNESS FOR A PARTICULAR PURPOSE, OR ANY OTHER MATTERS WITH RESPECT TO THE SALE OF L&M PRODUCT(S) AND ALL IMPLIED WARRANTIES OF MERCHANTABILITY OR FITNESS FOR A PARTICULAR PURPOSE ARE HEREBY DISCLAIMED. IN NO EVENT WILL L&M'S LIABILITY INCLUDE ANY SPECIAL, INCIDENTAL, CONSEQUENTIAL OR PUNITIVE DAMAGES, EVEN IF L&M KNEW OF THE LIKELIHOOD OF SUCH DAMAGES.

Any action or lawsuit for breach of the limited warranty in these L&M terms and conditions must be commenced in Minnesota. This warranty supersedes all previously published warranties.

MESABI® PRODUCT SPECIFIC WARRANTY

Covers:

- Radiators
- Cores
- Air-To-Air Coolers
- Low Pressure Oil Coolers & Fuel Coolers
(maximum 50 psi/345 kPa)

In addition to the MESABI® General Warranty, L&M Radiator further warrants the MESABI® heat exchangers listed above against seal leakage during normal operation for 48 months from date of invoice.

Standard Parts of a Typical MESABI® Radiator Core

SINGLE UPSET TUBE

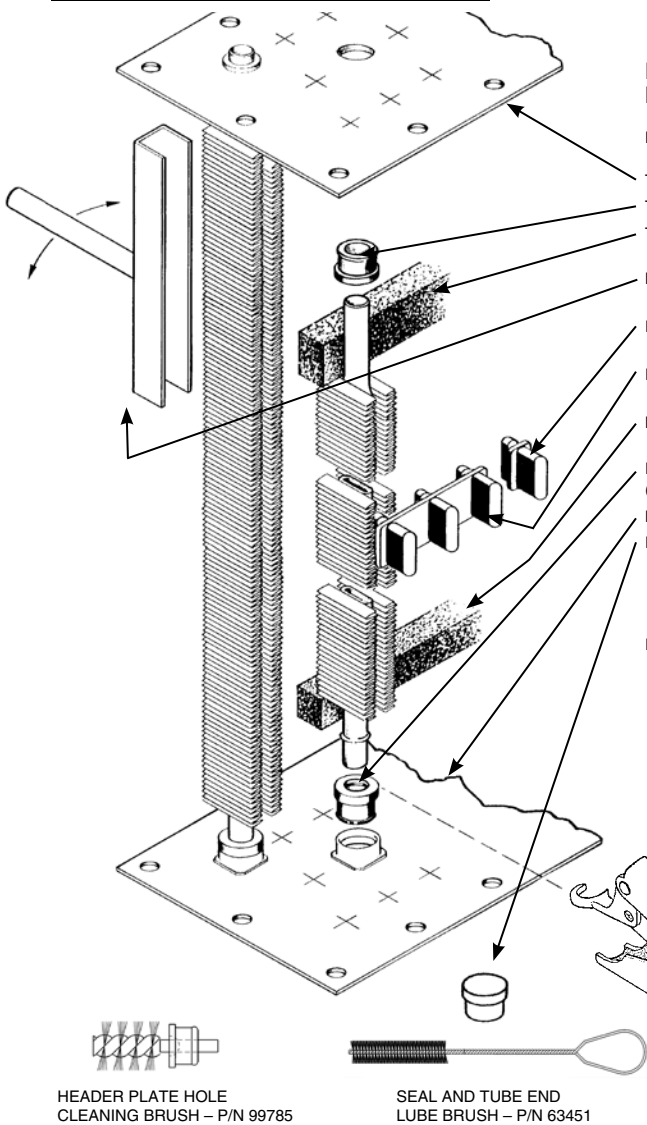

Exploded view of a typical MESABI® water jacket core

DESCRIPTION	PART NO.
TOP HEADER PLATE (bolted design)	_____
TOP RUBBER SEAL (see chart below)	_____
TOP FELT AIR BAFFLE (core width)	33082
BREAKER TOOL (for freeing tubes from rubber seal)	37239
RUBBER TUBE STAY (for staggered MESABI Cores only)	'F' 33335
RUBBER TUBE STAY END PIECE (for staggered cores only)	'H' 39292
RUBBER TUBE STAY END PIECE (for staggered cores only)	'F' 33085
RUBBER TUBE STAY END PIECE (for staggered cores only)	'H' 39300
BOTTOM FELT AIR BAFFLE (core width)	33083
RUBBER SEAL – LOCKING GROOVE (see chart and section view below)	_____
BOTTOM HEADER PLATE (bolted design)	_____
RUBBER PLUG	96630
<i>Note: Plugs are for temporary plugging of ferrule holes until replacement tubes can be installed. Plugs must be installed dry and are not recommended for systems operating over 15 P.S.I.</i>	
INSTALLATION TOOL (for removing and installing tubes)	48350

Note: Plugs are for temporary plugging of ferrule holes until replacement tubes can be installed. Plugs must be installed dry and are not recommended for systems operating over 15 P.S.I.

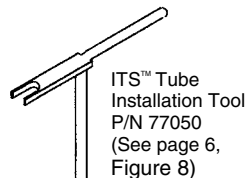

HEADER PLATE HOLE CLEANING BRUSH – P/N 99785

SEAL AND TUBE END LUBE BRUSH – P/N 63451

SEAL & LUBE CHART

If you are not sure of your core style, contact L&M Customer Service.

Core Style	Top Seal	Bottom Seal	Lube P/N
F (coolant)	WT	WB	113230.99
H (coolant)	WT	WB	113230.99
L (coolant)	WT	WB	113230.99
M (coolant)	WT	WB	113230.99
V (coolant)	WT	WB	113230.99
Locomotive*	35780	87530	113230.99
Air-to-Air*	35780	87530	107271.99
Oil Cooler*	35780	87530	107271.99

*Air-to-Air, Oil Cooler and Locomotive can be any style of core above (F, H, L, M, V)

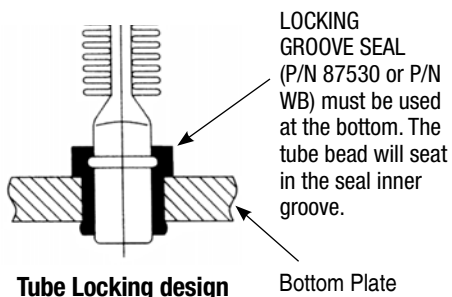

Additional Tube Styles

(Sold As Assemblies Only)



ITS™ (Individual Tube Support) Used on H, L, and V style cores

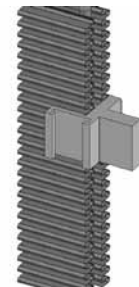

STAY Used on "L" style cores

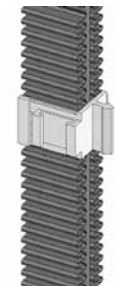

STAY Used on "M" style cores

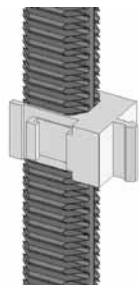

STAY Used on "V" style cores

Cleaning

STANDARD EXTERNAL CLEANING

To maintain efficiency and assure maximum life of a MESABI® Core, reasonable care must be taken when cleaning.

Most radiator shops use a hot alkaline soap, caustic soda or chemical additives in their boil-out tanks, which attacks solders. If a MESABI® tube is soaked in such a solution, the solder bond between the finning and tube will be adversely affected. If it is known that the particular solution used is not harmful to solder, then it will not hurt the solder used on the MESABI® tube. Be sure to completely rinse the cleaned tube/core in clean water after removing from the boil-out tank.

In most cases, it may be best to blow out any dry dirt with a high pressure air gun prior to washing the core with a high pressure hot water washer.

For general external cleaning, a high pressure, hot water washer (with or without soap) can be used at pressures up to 1200 psi (8274 KPa). **(CAUTION! To prevent fin deformation, you must stay a few inches away from the core and spray straight into the core not at an angle. If the cooler is still in the machine, you may have to use an offset angled nozzle so that you can spray straight into the core. If there is any doubt, try your cleaning method on a small portion of the core first.)** It is important to start on the air exit side. Work from the top to the bottom. Concentrate on small areas and work slowly. Wash until the water exiting the opposite side is free from dirt and debris. Complete this side and then repeat the process from the other side.

EPOXY-COATED CORES

Epoxy-coated cores must be cleaned with care to assure the coating is not damaged.

1. A high pressure hot water washer can normally be used. Use a “fresh” water supply. Water temperature should not exceed 180°F. Do not steam clean. The nozzle should be kept approximately 12 inches away from the core.

CAUTION! We do not recommend a pressure rating because as epoxy ages the coating does become brittle and might be damaged at higher pressures. We recommend that you try your cleaning method on a portion of a single tube first.

2. Wash the core thoroughly and methodically, starting at the top and working towards the bottom. Do not wash in one area for extended periods. The core will be clean when the water exiting the core is clean.
3. Blow off excess water with air.

Epoxy coatings are not meant for submergent duty. L&M Radiator does not warrant against corrosion, but this coating, properly cared for, will help increase the service life and efficiency of your cooling system.

INTERNAL CLEANING

In most cases just flushing the inside of the tubes with a high pressure hot water washer, with soap, will do the job. Rinse thoroughly with clean water.

Tube Removal

HELPFUL HINTS:

- Clean the core prior to removing tubes.
- To avoid bending or kinking tube ends, reduce the angle of the tube as it's being pulled from the top seal.
- If the core has a center tank, remove the top core tubes and seals first.
- If the core has an ITS™ (Individual Tube Support) or stay system with support bars, mark the bars front and back before removing, to ease reassembly.
- To assist in the removal process, spray WD-40 on the top end of tubes.
- If tubes are difficult to remove, try using the breaker tool and removal tool simultaneously.

STEP 1.

Loosen the tube by using Breaker Tool, L&M P/N 37239, as shown in **Fig. 1**. The Breaker Tool should be placed at top or bottom, not at middle when freeing tube from seal. Lightly twist the tube back and forth, to loosen tube from seals.

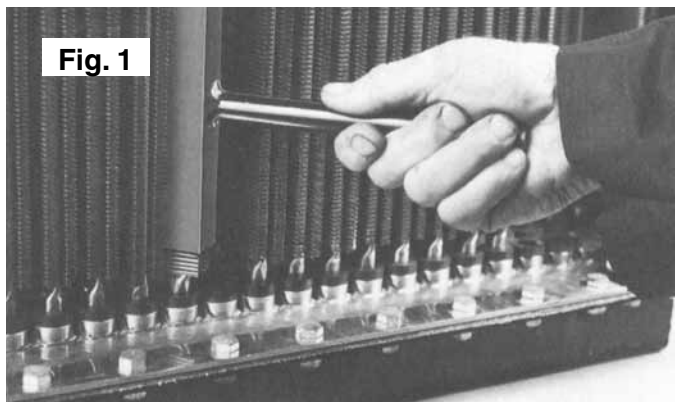

STEP 2.

After tube is free, place upper jaw of Installation Tool P/N 48350 around the round portion of tube, just below the flattened portion. Place lower jaw on top of bottom seal, see **Fig. 2**. Squeeze handles of tool together and raise tube only enough to clear bottom seal.

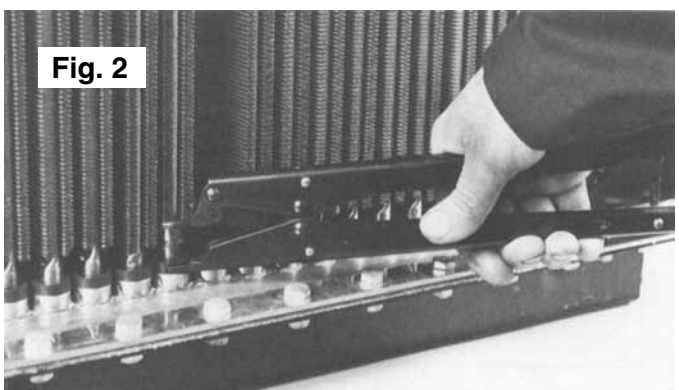

Tube Removal (continued)

STEP 3.

Put down tool and swing tube out just far enough to allow it to be pulled down and out of its top seal, as shown in **Fig. 3**.

Remove all tubes in the row, repeating the above procedure.

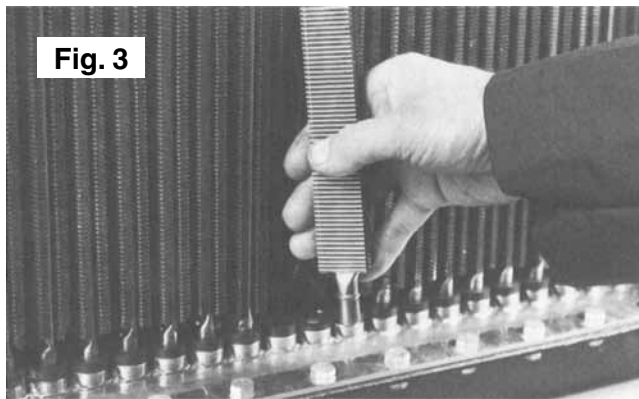

If you are working with any of L&M's ITS™ or stay systems with interlocking tabs, the tube must be raised high enough so that the interlocking tab clears the adjacent groove, as shown in **Fig. 4**.

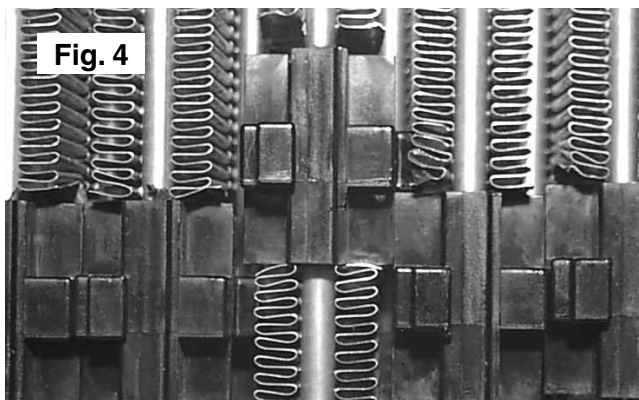

Cleaning Tube Ends

Before the original tubes are reinstalled, the tube ends must be clean of foreign material. L&M recommends polishing the tube ends with a polishing wheel (Grainger #5A725 – use Qty. 5 together) and a copper polishing compound (Grainger #3W769).

If the debris cannot be removed by polishing, L&M recommends using a piece of fine grit emery cloth or steel wool. If there is a lot of debris on the tube ends, use a 6" or 8" diameter wire wheel brush with a wire size of .006 or .008. Larger diameter wire sizes could damage the tube ends. Try installing a tube.

If it does not slide easily into the top and bottom seals, try polishing the tube ends as per above.

Seal Installation

HELPFUL HINTS:

- L&M recommends installing new MESABI® seals when tubes are removed.
- After removing the old seals, clean the plate holes of any foreign debris with L&M P/N 99785 header plate hole cleaning brush placed in an electric or air drill.
- Clean out inside of tanks and blow out plate holes with air.
- Install new seals in clean dry holes. **Do not apply any lubricant to header plate holes.**
- If the core has a center tank, do not install seals at the bottom of the top core until all the tubes are installed in the bottom core.
- For ease of seal installation, soak seals in hot water just prior to installing.
- Make sure you use proper seal part number (see Seal & Lube Chart on page 3).

With your thumb, start the new MESABI® seals into the holes and push them part way in. Care must be taken not to install seals too far into the header plate. A properly installed seal has a crowned or convex top surface, and the tube hole is slightly flared at the opening. A seal that is installed too far into the header has a concave top surface and the tube hole is noticeably smaller in diameter as shown in **Fig.5**. Over-installed seals will make tube installation more difficult and are much more likely to be damaged during tube installation.

The use of a hammer directly on the seal can easily cause seals to be installed too far into the header plate. L&M recommends the use of a flat plate 3/8" x 3" x 6" placed over the seals. Hitting with a rubber mallet will allow the seals to be properly installed.

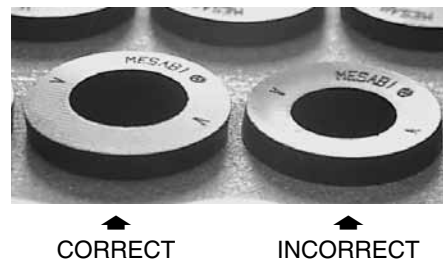

Fig. 5

ON THE LEFT:
Properly installed seal.

RIGHT:
Seal installed too far into header.

Lubricating Seals and Tube Ends

For ease of tube installation and to minimize the chance of scuffing or tearing rubber seals during tube installation, both top and bottom seals and both tube ends must be thoroughly lubricated, using L&M lube (see Seal & Lube Chart on page 3 for proper lube part number). Using a 1/2" diameter brush (L&M P/N 63451) and a minimal amount of lubricant, apply a thin film into each seal hole and onto each tube end.

Tube Installation

CAUTION! If a tube seems difficult to install into a seal, **STOP** and figure out **WHY!** One of the following reasons could be the answer.

1. A tube or seal with inadequate lubrication.
2. Improperly installed seal that could be pushed too far into the header plate hole.
3. Damaged tube end.
4. Trying to insert the tube into the seal at too steep of an angle.
5. Tube is not centered in seal.

NOTE: If, for any of the above reasons, a tube is difficult to install, the seal should be removed and inspected for any scuffing marks, tears, or cuts. If there is any doubt, replace the seal.

HELPFUL HINTS:

- If you are working with a center tank core, the bottom core must be assembled before the top core.
- Minimize the angle of the tube as it's being installed into the top seal.
- Make sure the tube is centered in the bottom seal before any force is applied to pull or push into place.
- For ease of tube installation, install the tubes behind the side member gussets in each row first. Install the tubes behind the left side gussets, working towards the core center. Then, going to the far right hole, in the same row, install the tubes working towards the core center.
- Individual rubber tube stays and, in some cases, tube stay ends are necessary to interlock the tubes. For part numbers see page 3. If more detailed information is required for proper assembly of cores using tube stays and tube stay ends, contact one of the L&M manufacturing facilities listed on back page.
- If your core style includes plastic tube supports, see page 7 for ITS™ or stay orientation prior to starting.

STEP 1.

To minimize installation angle, tubes in any given row must be installed from the closest header plate edge.

Use a minimum of angle and a slight twisting, pushing motion, to push the top end of the tube into the top seal. Push it far enough in so the bottom of the tube clears the top of the bottom seal.

If you are working with any of L&M's ITS™ or stay systems, you will need to insert the tube far enough into the top seal to allow clearance for the tabs to be aligned with the grooves when the tube is pulled down into the bottom seal (see **Figs. 4. and 6.**). Please note that when ITS™ or stays with interlocking tabs and grooves are present, the bottom end of the tube should be centered in the seal and then pulled down slightly into the seal so that the tabs engage the adjacent grooves.

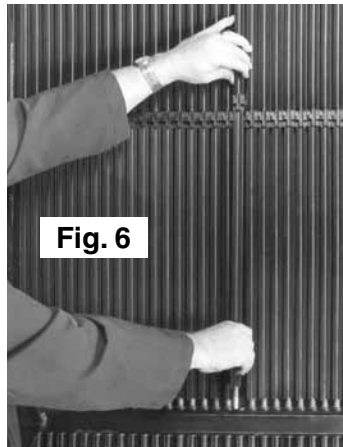

Fig. 6

NOTE: See page 7 for ITS™ or stay orientation in the core.

STEP 2.

Center bottom end of tube into respective seal in the bottom header plate. Then, push tube

down and into seal until the formed bead is seated into the locking groove of the bottom seal.

This may be done by grasping tubes by hand and pulling the tube downward until seated, or by using Installation Tool, L&M P/N 48350.

This tool has a semicircular form on the end of the handle. Place this end on the formed bead of the tube and push downward until seated, as shown in **Fig. 7.**

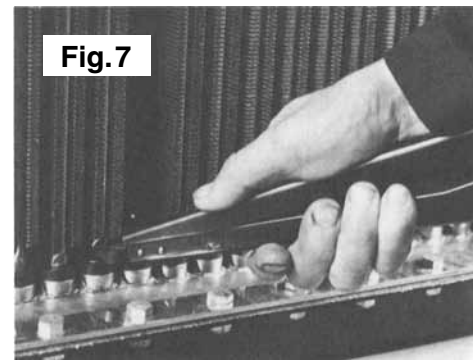

Fig. 7

Now, complete the row of tubes. Precaution should be taken to make sure formed bead is seated into bottom seal, and that the tubes are straight and aligned to assure maximum air flow.

If you are working with an ITS™ system (refer to page 3 and page 7, **Fig. 9,** for identification), use L&M tube installation tool P/N 77050 to pull the tube into the bottom seal. (See **Fig. 8.**) Hook the slotted end of the tool behind the front tab on the ITS™ tube support. Using the tool and your free hand, center the bottom end of the tube into the bottom seal. At the same time guide the dovetail slots into the tabs on the ITS™ tube support. Once in place, and with the tool P/N 77050 still hooked onto the ITS™ tube support, pull the tube into the bottom seal until the formed

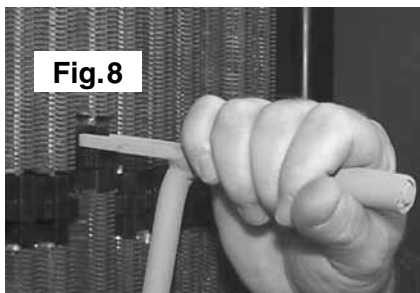

Fig. 8

bead is seated into the locking groove of the bottom seal. Push the remaining tubes in this row. Use the same procedure on all remaining rows except the front side row.

Tube Installation (continued)

STEP 2. (CONTINUED)

Tube Support Orientation

All illustrations front side as viewed from top.

A. ITS™ (can be used on H, L, or V style cores)

Make sure the tabs on the ITS tube supports are facing to the front and to the right.

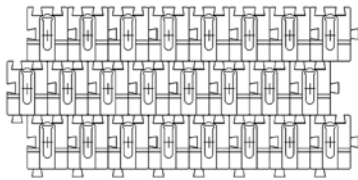

FRONT

Fig. 9

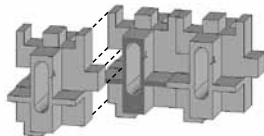

B. "L" Stay

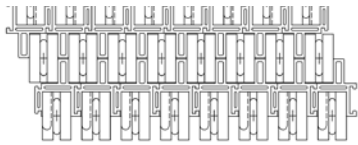

FRONT

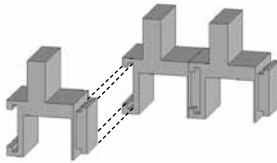

C. "M" Stay

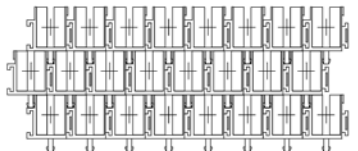

FRONT

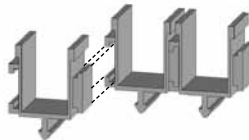

D. "V" Stay

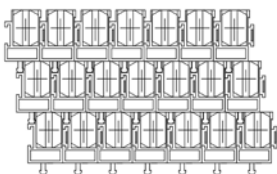

FRONT

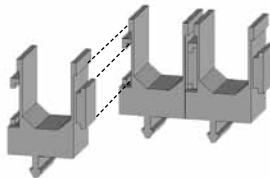

NOTE: If you are working with an older stay style that has rubber tube stays (see Exploded View page 3) and need assembly assistance, please contact L&M Customer Service.

STEP 3.

Before you install the front side row, install the felt air baffles.

Caution! To prevent seal leaks, do not allow the felt baffles to be pushed (top) or pulled (bottom) into the seal hole when installing the front row of tubes.

STEP 4. (If applicable)

If you are working with the ITS™ or stay support system, install the appropriate support bar as shown in Fig. 10.

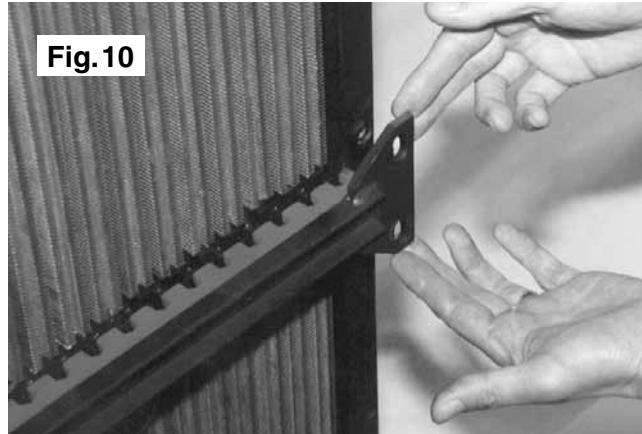

The support bar part number has been stamped on the outside face. Use the L&M Radiator Technical Drawing and Parts List for proper installation. Using a rubber mallet, gently tap the bar into place and secure to the side member.

PRESSURE TESTING

Pressure testing procedure that follows recommends testing to 15 psi (103 kPa). You should test to pressure rating specified on tag attached to your cooler. If there is no pressure rating specified, please contact L&M customer service with the part number of your cooler.

(Caution: Always bring air pressure up slowly and always wear protective gear)

1. Pressurize with compressed air to 15 psi (103 kPa) and submerge in water.
2. Seal any leaks at the test fittings and/or cover plates.
3. Repair any other leaks as needed.
4. Cycle test after successful initial test. Hold pressure at 15 psi (103 kPa) for 15 minutes. Note that the time starts after all leaks are fixed and air bubbles have subsided. Cycle to zero psi and pressure back up to 15 psi (103 kPa). Hold at 15 psi (103 kPa) for one minute. Repeat three more times and then hold the last cycle pressure at 15 psi (103 kPa) for five minutes. Should any leaks appear, fix them, and start the cycle test over.

If you have any questions regarding the procedures described in this Service Manual, please contact L&M Radiator and ask for Customer Service. See back page for contact information.

MESABI® is the world standard for heat exchanger reliability



L&M RADIATOR FACTORY-DIRECT SALES AND SERVICE

Because so many of our radiators and heat exchangers are a custom design, all sales are on a factory-direct basis. This assures that our customers receive a product that meets their cooling/heating requirements, offered to them at the least possible price.

We ship most parts within 24-hours. On-site technical and engineering assistance is available almost anywhere in the world within a few days notice.



L&M QUALITY POLICY

"The Quality Policy of L&M Radiator is to produce a quality engineered, quality manufactured product through continuous improvement that we deliver to the customer's satisfaction."



Manufactured and distributed by:

L&M Radiator

Toll Free: 800-346-3500 (U.S.A. and Canada)
Web Site: www.mesabi.com Email: cool@mesabi.com

WORLD HEADQUARTERS

L&M Radiator, Inc.
1414 East 37th Street
Hibbing, Minnesota 55746 U.S.A.
Telephone: (218) 263-8993
Fax: (218) 263-8234

ISO 9001:2008
CERTIFIED

UNITED STATES



L&M Radiator, Inc.
Hibbing, Minnesota U.S.A.



L&M Radiator, Inc.
Independence, Iowa U.S.A.



L&M Radiator, Inc.
El Paso, Texas U.S.A.



L&M Radiator, Inc.
Yankton, South Dakota U.S.A.

MEXICO



L y M de Mexico S.A. de C.V.
Calle De La Plata y Los Nogales
Parque Industrial
Hermosillo, Sonora, Mexico
Telephone: 011-52-662-251-0480
Fax: 011-52-662-251-0638
Email: ventas@lym.com.mx

AUSTRALIA



L&M Radiator Pty. Ltd.
Cnr. Kew & Kathleen Streets
Welshpool, Western Australia 6016
Telephone: +61-8-93616855
Fax: +61-8-94703075
Email: cool@mesabi.com.au

MESABI® and RTTS® are registered trademarks of L&M Radiator, Inc. System Protector™, BOSS™, V-Tube Core™, CSC™ and Captured Seal Cooler™ are trademarks of L&M Radiator, Inc. Copyright © 2008 L&M Radiator, Inc.

SERVICE MANUAL

MESABI®

COPPER TUBE

- **RADIATORS**
- **CORES**
- **AIR-TO-AIR COOLERS**
- **LOW PRESSURE OIL COOLERS & FUEL COOLERS (MAXIMUM 50 PSI/345 KPA)**

Please read and follow instructions carefully before proceeding with any service work and/or repairs. Consult factory before proceeding with any possible warranty claims.

CONTENTS

MESABI® Radiator Cores

Warranty	Page 2
Standard Parts & Tools	Page 3
External Cleaning	Page 4
Epoxy Coated Core External Cleaning	Page 4
Internal Cleaning	Page 4
Removing Tubes	Pages 4 & 5
Cleaning Tube Ends	Page 5
Installing Seals	Page 5
Lubrication	Page 5
Installing Tubes	Pages 6 & 7
Pressure Testing	Page 7
Manufacturing & Parts Facilities	Page 8

CONTACT L&M'S CUSTOMER SERVICE DEPARTMENT PRIOR TO REPAIRS WHERE WARRANTY CLAIM IS A POSSIBILITY. FAILURE TO DO SO MAY VOID WARRANTY.

MESABI® GENERAL WARRANTY

Consult L&M before proceeding with warranty claims or repairs. Failure to do so may void this limited warranty. This limited warranty allocates the risk of failure of the product(s) between the buyer and L&M and is reflected in the purchase price.

L&M warrants that MESABI® products will conform to L&M's written quotation specifications and drawings. MESABI® framework components are warranted for 18 months from the date of invoice against defects in materials and workmanship during normal usage. L&M warranty against seal leakage during normal operation is stated in individual product literature.

L&M's liability is limited to the rework or replacement (at L&M's sole option) of products or parts manufactured by L&M that are determined by L&M to be defective in workmanship or material or do not meet L&M's quoted specifications.

L&M product warranty does not apply if the product has been subjected to abnormal use or conditions, unauthorized modifications or repair, corrosion, misuse, neglect, abuse, accident, improper installation, or other acts which are not the fault of L&M, including damage caused by shipping.

L&M does not warranty products incorporated into L&M products that are not manufactured by L&M. Buyer's sole recourse with respect to such products will be subject to the warranty of the individual manufacturer.

OTHER THAN AS STATED HEREIN, L&M MAKES NO REPRESENTATION OR WARRANTY OF ANY KIND, EXPRESSED OR IMPLIED, AS TO MERCHANTABILITY OR FITNESS FOR A PARTICULAR PURPOSE, OR ANY OTHER MATTERS WITH RESPECT TO THE SALE OF L&M PRODUCT(S) AND ALL IMPLIED WARRANTIES OF MERCHANTABILITY OR FITNESS FOR A PARTICULAR PURPOSE ARE HEREBY DISCLAIMED. IN NO EVENT WILL L&M'S LIABILITY INCLUDE ANY SPECIAL, INCIDENTAL, CONSEQUENTIAL OR PUNITIVE DAMAGES, EVEN IF L&M KNEW OF THE LIKELIHOOD OF SUCH DAMAGES.

Any action or lawsuit for breach of the limited warranty in these L&M terms and conditions must be commenced in Minnesota. This warranty supersedes all previously published warranties.

MESABI® PRODUCT SPECIFIC WARRANTY

Covers:

- Radiators
- Cores
- Air-To-Air Coolers
- Low Pressure Oil Coolers & Fuel Coolers
(maximum 50 psi/345 kPa)

In addition to the MESABI® General Warranty, L&M Radiator further warrants the MESABI® heat exchangers listed above against seal leakage during normal operation for 48 months from date of invoice.

Standard Parts of a Typical MESABI® Radiator Core

SINGLE UPSET TUBE

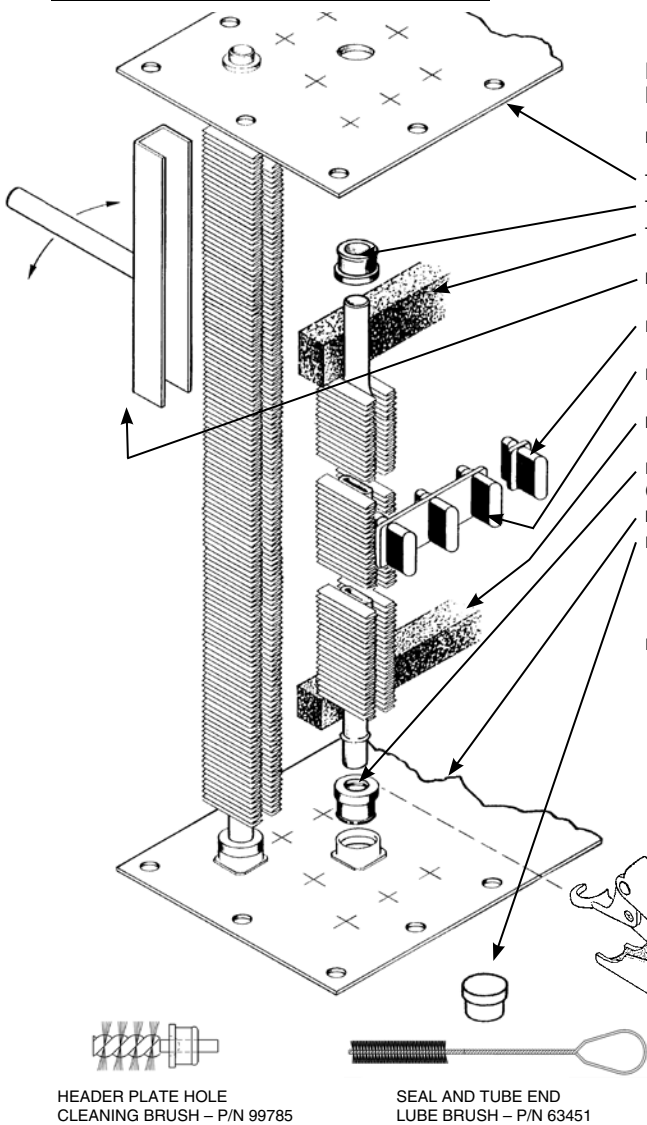

Exploded view of a typical MESABI® water jacket core

DESCRIPTION	PART NO.
TOP HEADER PLATE (bolted design)	_____
TOP RUBBER SEAL (see chart below)	_____
TOP FELT AIR BAFFLE (core width)	33082
BREAKER TOOL (for freeing tubes from rubber seal)	37239
RUBBER TUBE STAY (for staggered MESABI Cores only)	'F' 33335
RUBBER TUBE STAY END PIECE (for staggered cores only)	'H' 39292
RUBBER TUBE STAY END PIECE (for staggered cores only)	'F' 33085
RUBBER TUBE STAY END PIECE (for staggered cores only)	'H' 39300
BOTTOM FELT AIR BAFFLE (core width)	33083
RUBBER SEAL – LOCKING GROOVE (see chart and section view below)	_____
BOTTOM HEADER PLATE (bolted design)	_____
RUBBER PLUG	96630
<i>Note: Plugs are for temporary plugging of ferrule holes until replacement tubes can be installed. Plugs must be installed dry and are not recommended for systems operating over 15 P.S.I.</i>	
INSTALLATION TOOL (for removing and installing tubes)	48350

Note: Plugs are for temporary plugging of ferrule holes until replacement tubes can be installed. Plugs must be installed dry and are not recommended for systems operating over 15 P.S.I.

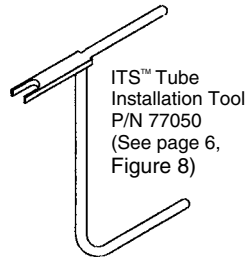

HEADER PLATE HOLE CLEANING BRUSH – P/N 99785

SEAL AND TUBE END LUBE BRUSH – P/N 63451

SEAL & LUBE CHART

If you are not sure of your core style, contact L&M Customer Service.

Core Style	Top Seal	Bottom Seal	Lube P/N
F (coolant)	WT	WB	113230.99
H (coolant)	WT	WB	113230.99
L (coolant)	WT	WB	113230.99
M (coolant)	WT	WB	113230.99
V (coolant)	WT	WB	113230.99
Locomotive*	35780	87530	113230.99
Air-to-Air*	35780	87530	107271.99
Oil Cooler*	35780	87530	107271.99

*Air-to-Air, Oil Cooler and Locomotive can be any style of core above (F, H, L, M, V)

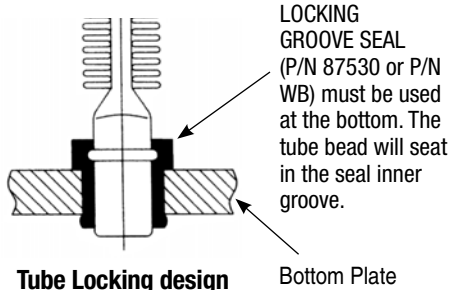

Additional Tube Styles

(Sold As Assemblies Only)

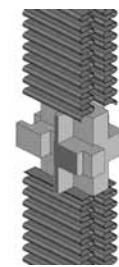

ITS™ (Individual Tube Support) Used on H, L, and V style cores

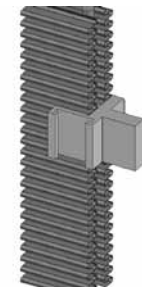

STAY Used on "L" style cores

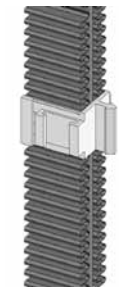

STAY Used on "M" style cores

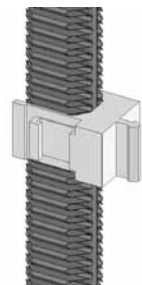

STAY Used on "V" style cores

Cleaning

STANDARD EXTERNAL CLEANING

To maintain efficiency and assure maximum life of a MESABI® Core, reasonable care must be taken when cleaning.

Most radiator shops use a hot alkaline soap, caustic soda or chemical additives in their boil-out tanks, which attacks solders. If a MESABI® tube is soaked in such a solution, the solder bond between the finning and tube will be adversely affected. If it is known that the particular solution used is not harmful to solder, then it will not hurt the solder used on the MESABI® tube. Be sure to completely rinse the cleaned tube/core in clean water after removing from the boil-out tank.

In most cases, it may be best to blow out any dry dirt with a high pressure air gun prior to washing the core with a high pressure hot water washer.

For general external cleaning, a high pressure, hot water washer (with or without soap) can be used at pressures up to 1200 psi (8274 KPa). **(CAUTION! To prevent fin deformation, you must stay a few inches away from the core and spray straight into the core not at an angle. If the cooler is still in the machine, you may have to use an offset angled nozzle so that you can spray straight into the core. If there is any doubt, try your cleaning method on a small portion of the core first.)** It is important to start on the air exit side. Work from the top to the bottom. Concentrate on small areas and work slowly. Wash until the water exiting the opposite side is free from dirt and debris. Complete this side and then repeat the process from the other side.

EPOXY-COATED CORES

Epoxy-coated cores must be cleaned with care to assure the coating is not damaged.

1. A high pressure hot water washer can normally be used. Use a “fresh” water supply. Water temperature should not exceed 180°F. Do not steam clean. The nozzle should be kept approximately 12 inches away from the core.

CAUTION! We do not recommend a pressure rating because as epoxy ages the coating does become brittle and might be damaged at higher pressures. We recommend that you try your cleaning method on a portion of a single tube first.

2. Wash the core thoroughly and methodically, starting at the top and working towards the bottom. Do not wash in one area for extended periods. The core will be clean when the water exiting the core is clean.
3. Blow off excess water with air.

Epoxy coatings are not meant for submergent duty. L&M Radiator does not warrant against corrosion, but this coating, properly cared for, will help increase the service life and efficiency of your cooling system.

INTERNAL CLEANING

In most cases just flushing the inside of the tubes with a high pressure hot water washer, with soap, will do the job. Rinse thoroughly with clean water.

Tube Removal

HELPFUL HINTS:

- Clean the core prior to removing tubes.
- To avoid bending or kinking tube ends, reduce the angle of the tube as it's being pulled from the top seal.
- If the core has a center tank, remove the top core tubes and seals first.
- If the core has an ITS™ (Individual Tube Support) or stay system with support bars, mark the bars front and back before removing, to ease reassembly.
- To assist in the removal process, spray WD-40 on the top end of tubes.
- If tubes are difficult to remove, try using the breaker tool and removal tool simultaneously.

STEP 1.

Loosen the tube by using Breaker Tool, L&M P/N 37239, as shown in Fig. 1. The Breaker Tool should be placed at top or bottom, not at middle when freeing tube from seal. Lightly twist the tube back and forth, to loosen tube from seals.

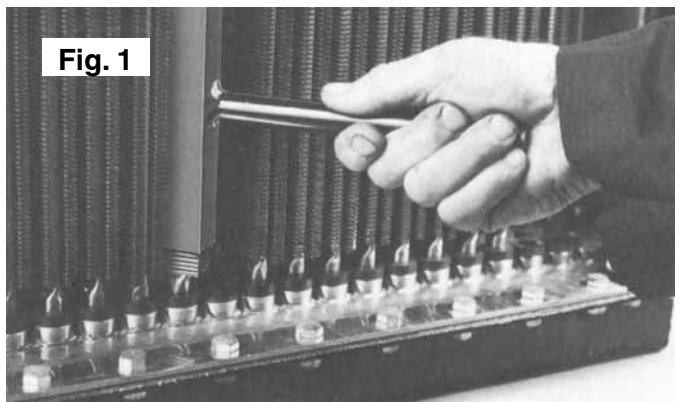

STEP 2.

After tube is free, place upper jaw of Installation Tool P/N 48350 around the round portion of tube, just below the flattened portion. Place lower jaw on top of bottom seal, see Fig. 2. Squeeze handles of tool together and raise tube only enough to clear bottom seal.

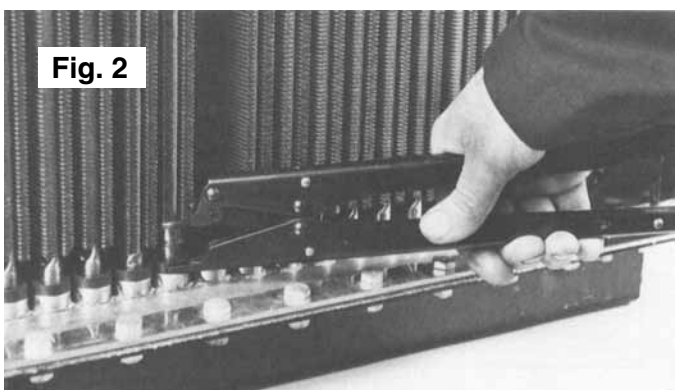

Tube Removal (continued)

STEP 3.

Put down tool and swing tube out just far enough to allow it to be pulled down and out of its top seal, as shown in **Fig. 3**.

Remove all tubes in the row, repeating the above procedure.

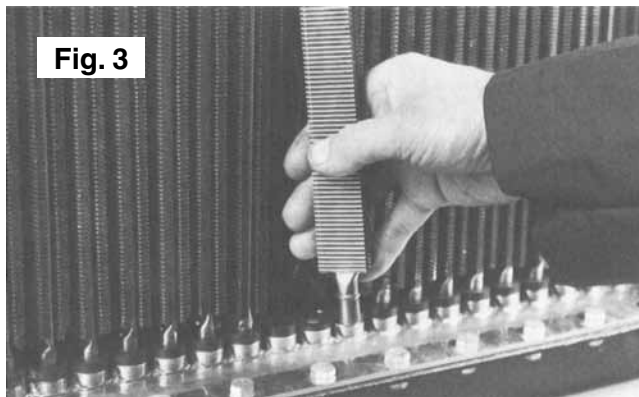

If you are working with any of L&M's ITS™ or stay systems with interlocking tabs, the tube must be raised high enough so that the interlocking tab clears the adjacent groove, as shown in **Fig. 4**.

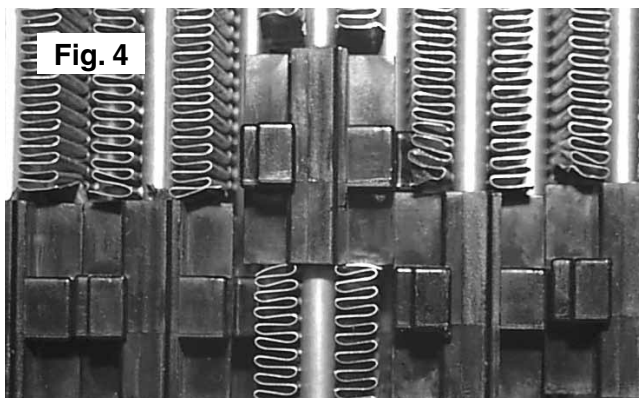

Cleaning Tube Ends

Before the original tubes are reinstalled, the tube ends must be clean of foreign material. L&M recommends polishing the tube ends with a polishing wheel (Grainger #5A725 – use Qty. 5 together) and a copper polishing compound (Grainger #3W769).

If the debris cannot be removed by polishing, L&M recommends using a piece of fine grit emery cloth or steel wool. If there is a lot of debris on the tube ends, use a 6" or 8" diameter wire wheel brush with a wire size of .006 or .008. Larger diameter wire sizes could damage the tube ends. Try installing a tube.

If it does not slide easily into the top and bottom seals, try polishing the tube ends as per above.

Seal Installation

HELPFUL HINTS:

- L&M recommends installing new MESABI® seals when tubes are removed.
- After removing the old seals, clean the plate holes of any foreign debris with L&M P/N 99785 header plate hole cleaning brush placed in an electric or air drill.
- Clean out inside of tanks and blow out plate holes with air.
- Install new seals in clean dry holes. **Do not apply any lubricant to header plate holes.**
- If the core has a center tank, do not install seals at the bottom of the top core until all the tubes are installed in the bottom core.
- For ease of seal installation, soak seals in hot water just prior to installing.
- Make sure you use proper seal part number (see Seal & Lube Chart on page 3).

With your thumb, start the new MESABI® seals into the holes and push them part way in. Care must be taken not to install seals too far into the header plate. A properly installed seal has a crowned or convex top surface, and the tube hole is slightly flared at the opening. A seal that is installed too far into the header has a concave top surface and the tube hole is noticeably smaller in diameter as shown in **Fig.5**. Over-installed seals will make tube installation more difficult and are much more likely to be damaged during tube installation.

The use of a hammer directly on the seal can easily cause seals to be installed too far into the header plate. L&M recommends the use of a flat plate 3/8" x 3" x 6" placed over the seals. Hitting with a rubber mallet will allow the seals to be properly installed.

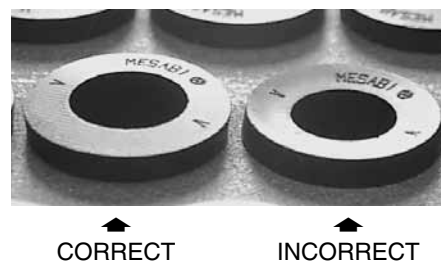

Fig. 5

ON THE LEFT:
Properly installed seal.

RIGHT:
Seal installed too far into header.

Lubricating Seals and Tube Ends

For ease of tube installation and to minimize the chance of scuffing or tearing rubber seals during tube installation, both top and bottom seals and both tube ends must be thoroughly lubricated, using L&M lube (see Seal & Lube Chart on page 3 for proper lube part number). Using a 1/2" diameter brush (L&M P/N 63451) and a minimal amount of lubricant, apply a thin film into each seal hole and onto each tube end.

Tube Installation

CAUTION! If a tube seems difficult to install into a seal, STOP and figure out WHY! One of the following reasons could be the answer.

1. A tube or seal with inadequate lubrication.
2. Improperly installed seal that could be pushed too far into the header plate hole.
3. Damaged tube end.
4. Trying to insert the tube into the seal at too steep of an angle.
5. Tube is not centered in seal.

NOTE: If, for any of the above reasons, a tube is difficult to install, the seal should be removed and inspected for any scuffing marks, tears, or cuts. If there is any doubt, replace the seal.

HELPFUL HINTS:

- If you are working with a center tank core, the bottom core must be assembled before the top core.
- Minimize the angle of the tube as it's being installed into the top seal.
- Make sure the tube is centered in the bottom seal before any force is applied to pull or push into place.
- For ease of tube installation, install the tubes behind the side member gussets in each row first. Install the tubes behind the left side gussets, working towards the core center. Then, going to the far right hole, in the same row, install the tubes working towards the core center.
- Individual rubber tube stays and, in some cases, tube stay ends are necessary to interlock the tubes. For part numbers see page 3. If more detailed information is required for proper assembly of cores using tube stays and tube stay ends, contact one of the L&M manufacturing facilities listed on back page.
- If your core style includes plastic tube supports, see page 7 for ITS™ or stay orientation prior to starting.

STEP 1.

To minimize installation angle, tubes in any given row must be installed from the closest header plate edge.

Use a minimum of angle and a slight twisting, pushing motion, to push the top end of the tube into the top seal. Push it far enough in so the bottom of the tube clears the top of the bottom seal.

If you are working with any of L&M's ITS™ or stay systems, you will need to insert the tube far enough into the top seal to allow clearance for the tabs to be aligned with the grooves when the tube is pulled down into the bottom seal (see **Figs. 4. and 6.**). Please note that when ITS™ or stays with interlocking tabs and grooves are present, the bottom end of the tube should be centered in the seal and then pulled down slightly into the seal so that the tabs engage the adjacent grooves.

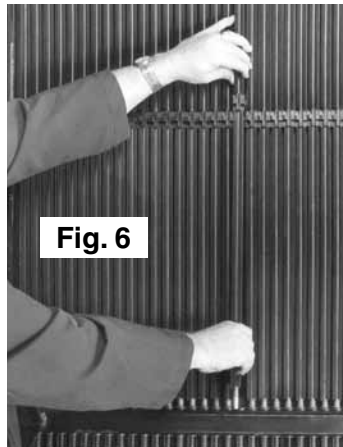

Fig. 6

NOTE: See page 7 for ITS™ or stay orientation in the core.

STEP 2.

Center bottom end of tube into respective seal in the bottom header plate. Then, push tube

down and into seal until the formed bead is seated into the locking groove of the bottom seal.

This may be done by grasping tubes by hand and pulling the tube downward until seated, or by using Installation Tool, L&M P/N 48350.

This tool has a semicircular form on the end of the handle. Place this end on the formed bead of the tube and push downward until seated, as shown in **Fig. 7.**

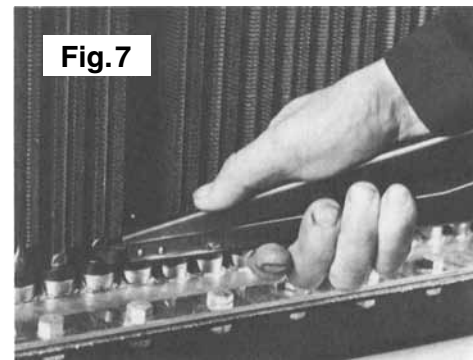

Fig. 7

Now, complete the row of tubes. Precaution should be taken to make sure formed bead is seated into bottom seal, and that the tubes are straight and aligned to assure maximum air flow.

If you are working with an ITS™ system (refer to page 3 and page 7, **Fig. 9,** for identification), use L&M tube installation tool P/N 77050 to pull the tube into the bottom seal. (See **Fig. 8.**) Hook the slotted end of the tool behind the front tab on the ITS™ tube support. Using the tool and your free hand, center the bottom end of the tube into the bottom seal. At the same time guide the dovetail slots into the tabs on the ITS™ tube support. Once in place, and with the tool P/N 77050 still hooked onto the ITS™ tube support, pull the tube into the bottom seal until the formed

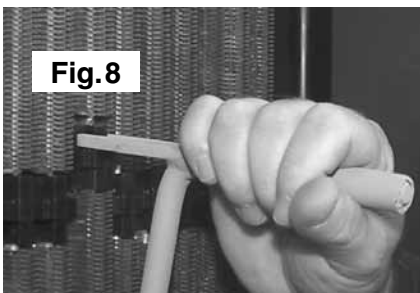

Fig. 8

bead is seated into the locking groove of the bottom seal. Push the remaining tubes in this row. Use the same procedure on all remaining rows except the front side row.

Tube Installation (continued)

STEP 2. (CONTINUED)

Tube Support Orientation

All illustrations front side as viewed from top.

A. ITS™ (can be used on H, L, or V style cores)

Make sure the tabs on the ITS tube supports are facing to the front and to the right.

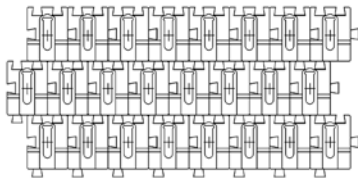

FRONT

Fig. 9

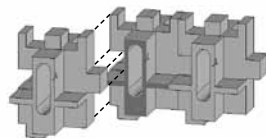

B. "L" Stay

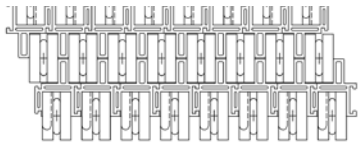

FRONT

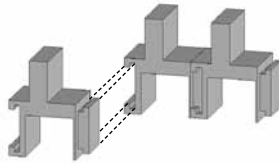

C. "M" Stay

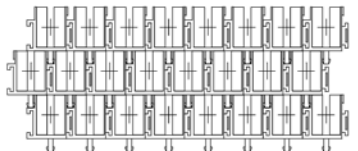

FRONT

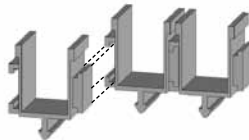

D. "V" Stay

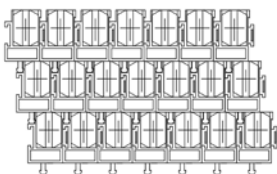

FRONT

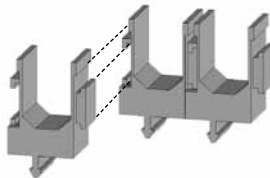

NOTE: If you are working with an older stay style that has rubber tube stays (see Exploded View page 3) and need assembly assistance, please contact L&M Customer Service.

STEP 3.

Before you install the front side row, install the felt air baffles.

Caution! To prevent seal leaks, do not allow the felt baffles to be pushed (top) or pulled (bottom) into the seal hole when installing the front row of tubes.

STEP 4. (If applicable)

If you are working with the ITS™ or stay support system, install the appropriate support bar as shown in Fig. 10.

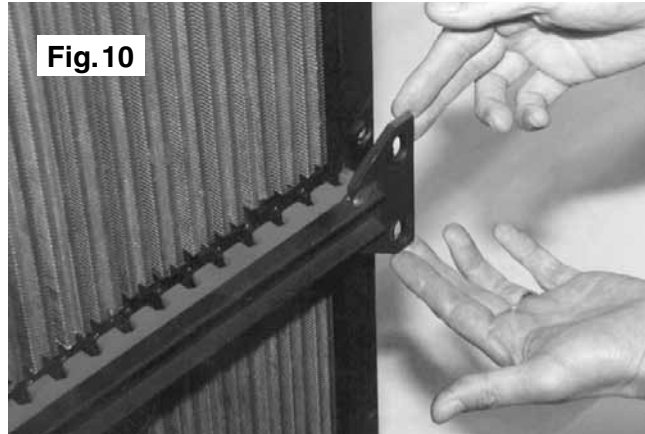

Fig. 10

The support bar part number has been stamped on the outside face. Use the L&M Radiator Technical Drawing and Parts List for proper installation. Using a rubber mallet, gently tap the bar into place and secure to the side member.

PRESSURE TESTING

Pressure testing procedure that follows recommends testing to 15 psi (103 kPa). You should test to pressure rating specified on tag attached to your cooler. If there is no pressure rating specified, please contact L&M customer service with the part number of your cooler.

(Caution: Always bring air pressure up slowly and always wear protective gear)

1. Pressurize with compressed air to 15 psi (103 kPa) and submerge in water.
2. Seal any leaks at the test fittings and/or cover plates.
3. Repair any other leaks as needed.
4. Cycle test after successful initial test. Hold pressure at 15 psi (103 kPa) for 15 minutes. Note that the time starts after all leaks are fixed and air bubbles have subsided. Cycle to zero psi and pressure back up to 15 psi (103 kPa). Hold at 15 psi (103 kPa) for one minute. Repeat three more times and then hold the last cycle pressure at 15 psi (103 kPa) for five minutes. Should any leaks appear, fix them, and start the cycle test over.

If you have any questions regarding the procedures described in this Service Manual, please contact L&M Radiator and ask for Customer Service. See back page for contact information.

MESABI® is the world standard for heat exchanger reliability



L&M RADIATOR FACTORY-DIRECT SALES AND SERVICE

Because so many of our radiators and heat exchangers are a custom design, all sales are on a factory-direct basis. This assures that our customers receive a product that meets their cooling/heating requirements, offered to them at the least possible price.

We ship most parts within 24-hours. On-site technical and engineering assistance is available almost anywhere in the world within a few days notice.



L&M QUALITY POLICY

"The Quality Policy of L&M Radiator is to produce a quality engineered, quality manufactured product through continuous improvement that we deliver to the customer's satisfaction."



Manufactured and distributed by:

L&M Radiator

Toll Free: 800-346-3500 (U.S.A. and Canada)
Web Site: www.mesabi.com Email: cool@mesabi.com

WORLD HEADQUARTERS

L&M Radiator, Inc.
1414 East 37th Street
Hibbing, Minnesota 55746 U.S.A.
Telephone: (218) 263-8993
Fax: (218) 263-8234

ISO 9001:2008
CERTIFIED

UNITED STATES



L&M Radiator, Inc.
Hibbing, Minnesota U.S.A.



L&M Radiator, Inc.
Independence, Iowa U.S.A.



L&M Radiator, Inc.
El Paso, Texas U.S.A.



L&M Radiator, Inc.
Yankton, South Dakota U.S.A.

MEXICO



L y M de Mexico S.A. de C.V.
Calle De La Plata y Los Nogales
Parque Industrial
Hermosillo, Sonora, Mexico
Telephone: 011-52-662-251-0480
Fax: 011-52-662-251-0638
Email: ventas@lym.com.mx

AUSTRALIA



L&M Radiator Pty. Ltd.
Cnr. Kew & Kathleen Streets
Welshpool, Western Australia 6016
Telephone: +61-8-93616855
Fax: +61-8-94703075
Email: cool@mesabi.com.au

MESABI® and RTTS® are registered trademarks of L&M Radiator, Inc. System Protector™, BOSS™, V-Tube Core™, CSC™ and Captured Seal Cooler™ are trademarks of L&M Radiator, Inc. Copyright © 2008 L&M Radiator, Inc.